



Miniature Railway Workshop Ltd.

www.miniaturerailwayworkshop.com

Miniature Railway Workshop, Unit 1a & 1b, New Line Road,
Kirkby-In-Ashfield, Nottingham, NG17 8JQ



Brochure 2023

Email. miniaturerailwayworkshop@gmail.com

Tel. +44 (0)7591 006642

Version 4.0 (06/03/2023)

£2 for printed version or free with purchase.



Proudly designed and manufactured in the UK

Registered office; Unit 1a & 1b, New Line Road, Kirkby-In-Ashfield, Nottingham, NG17 8JQ



2023 BROCHURE

Introduction	2
MRW Track Range, different track for different needs...	3
MRW Portable Track	7
5" Gauge Jubilee Range	8
7¼" Gauge Jubilee Range	12
Custom Radius Curved Jubilee Track Panels	20
Starter Packs of Jubilee Track	27
Semi-Permanent and Permanent Track Products	33
Permanent Profile Rail Products	38
Turntables	45
Locomotive Moving Products	47
Rolling Stock	50
Locomotives	56
Couplings and Braking	60
Miniature & Full Size Steam Accessories and Supplies	69
Workshop Materials and Tools	74
Repair & Refurbishment	78
Signs and Lineside Equipment	79
Publications	82
Postage and Collection	83

Introduction

Made right here: We design/develop/manufacture/dispatch from right here in the UK



From left - Daniel Mason (Managing Director) - John Mason (Director)
James Wright (Director) - Matt Cross (Production) - Paul Launders (Production)

Miniature Railway Workshop Ltd., is a UK company manufacturing and retailing miniature railway products and components, many of which are developed and made at our workshop here in Nottingham.

We want to bring miniature railways within reach of everyone, whether they have a large or small garden. Alternatively, we can also supply track to large sites for public events.

MRW is constantly looking for ways to help miniature railway enthusiasts enjoy their hobby. We strive to produce reliable and well designed products that you can trust to work well throughout their lifespan. Our track is currently available in 3½", 5" & 7¼" gauges, but we are working hard to increase our range and also offer other products applicable to both the model engineer and miniature railway enthusiast.





MRW Track Range, different track for different needs...

MRW offers a range of track options to suit the needs of the large majority of miniature railway enthusiasts and model engineers. MRW is best known for its Jubilee portable track range; a product tried, tested and trusted by hobbyists and commercial operators alike. Our Jubilee range is cleverly designed and suits a variety of customers perfectly, however it isn't right for everyone.

Over the past few years, we have been working hard to expand our range into permanent and semi-permanent track products that suit those who want a railway that they can lay for many years and rely on to be robust and hard-wearing throughout its life. For some customers, the detail really matters and we have worked hard to offer rail types that represent the look and feel of a real narrow gauge or full sized railway. On this basis, we now have three main track ranges to choose from.

Portable Track

Offered in two types, Jubilee and Click & Play, these products are designed to be laid for no more than a week or so at a time and can be laid in a matter of minutes. They can be laid anywhere where there is level and firm ground for temporary garden railways, for events and shows and in some instances, for commercial passenger carrying set-ups. They are easy to transport, quick to lay, but aspects of their design such as thin walled steel (Jubilee) or lightweight rail construction (Click & Play) make them unsuitable for long term exposure to the elements and very large locos.

Semi-Permanent Track

Semi-permanent track is suitable for leaving outside for long periods, but can be taken up and laid elsewhere whilst retaining its original shape and form. This type of track is perfect for gardens, estates and commercial operations where it might need to be lifted in the long term. Our newest range, named the 'Britannia' semi-permanent range, follows the set panel size system of the Jubilee, is robust in its welded panel design, is ready to lay in its pre-made panel form and can last the test of time due to its bar rail construction. Sections can also be removed with relative ease, allowing the layout of the railway to be changed, and the likes of points added at a later date. Whilst this track requires ballast, groundwork and maintenance, its rigid form helps to mitigate defects and this is an excellent choice for any mid to long term railway installation.

Permanent Track

Permanent track is built primarily using traditional profile rail, chairs and sleepers to hold the gauge, just like with full sized railways. It looks the part and mimics the feel of a full sized railway for customers who care about the details. To be successful in the long term, it requires excellent groundwork and dedicated maintenance to address ballast issues which form over time. Using larger rail profiles can reduce issues, so careful consideration should be taken during the planning process. MRW currently offer 16mm aluminium rail, with larger profiles available upon request.



MRW Portable Track

MRW portable track is designed to be regularly laid and taken up. It is not the intention of the designs to make a scale model of standard or narrow gauge track, but to make a reliable safe track that balances the constraints of scale against safety and to produce a design that is fit for purpose. MRW Jubilee track, with its slot together box steel fishplate system, makes the track very easy to lay and take up. It is well respected for its easy to understand system, robust construction and quality of design. We also offer a portable system called 'Click & Play.' This is a lightweight system designed by Colin Edmondson and is targeted towards small gardens and confined spaces, making it a fun product for the enthusiast. It is easy to lay and is enjoyed by customers across the world, much like other designs by Colin.

Why is it called Jubilee Track?

Jubilee Track is a common name given to portable narrow gauge railway track dating back over a century. Narrow gauge railways were used in many forms of industry including mines, quarries, construction sites, tunnelling, military campaigns, peat workings, engineering workshops, sugar plantations, canal dredging, salt works, permanent railway construction, sewage works, the list goes on....

The track MRW produces is a scaled down version of that early portable track and therefore we use the name Jubilee. You can use the MRW Jubilee track for both industrial use and passenger carriage but today we tend to focus on the movement of people rather than sewage!

Don't Just take our word for it!

"The track from you has been superb, particularly the point."



Ordered through our website, manufactured and dispatched in just weeks. 'Hoping to pop in a small siding off my 'Foxglove Railway' and the original track from yourselves has been superb, particularly the point.'

Photo and quote, Andy.

"Jubilee portable track laid in minutes, and giving hours of fun."



Patrick David
2 reviews · 8 photos

★★★★★ a week ago

Absolutely excellent service! I ordered a large quantity of 7 1/4" gauge track which arrived promptly and is made to the highest quality! Can't recommend MRW enough! Perfect for portable miniature railways such as mine, can't wait to start showing off the track at some GLMR events! Can't wait to see what they come up with next!

Photo and quote Patrick Allen / Owner / [GLMR - Portable Miniature Railway](#)

2023 BROCHURE AND PRICE LIST

"It was a dream to put together."



"I went and collected this lovely stack of portable track from Miniature Railway Workshop! It was a dream to put together and quickly expanded the track onto the front drive 😊 just in time for Flair Light Railway's first visiting locomotive!"

"Great service and a fantastic product 👍 loving my new portable track"

Photo and quote Foz Fosdike / Owner / Flair Light Railway



Miniature Railway Workshop is such a friendly company. The staff are really helpful and have kept Woolsey's Miniature Railway going. Whenever we have had a question they're always there to help out. Their track panels are so easy to put together and well made we would recommend them to anyone.

10/10

Photo and quote Thomas Woolsey / Owner / [Woolsey's Miniature Railway](#)

To see more reviews and leave one for yourself head to [Our Google Maps Page](#)

10 ¼”, 7¼”, 5” & 3 ½” Jubilee Track.

Jubilee Track is a portable range which started as 7 ¼" gauge but has expanded in scope to include all common miniature gauges - 10 ¼", 7¼", 5" & 3 ½". The track is designed to be laid and taken up regularly and both can be done in matter of minutes. All Jubilee Track panels supplied by Miniature Railway Workshop are interchangeable, meaning that they can be laid in any order. The flexibility in their arrangement allows them to be exceedingly suitable for specific space applications and you will be able to continue to expand your temporary railway with more track panels and points if desired.

Joining the track

Jubilee Track panels easily slot together with the fishplate from each section slotting inside of the opposing track panel rail.



CAD render of joining of Jubilee Track panels.

A “Track Panel Tie Bar” can be used to hold the sections together on curves where there is an increased risk of the sections parting with the passage of trains.

The Design

It is not the intention of the design to make a scale model of standard or narrow gauge track but to make a reliable safe track that balances the constraints of scale against safety and produces a design that is fit for purpose.



Transport and storage

The track panels are designed for easy transport, being an appropriate size to fit in most estate cars, trailers and vans.

The panels are lightweight, being less than 7kg each, (points and other panels may weigh more). The panels also stack easily to keep the space required to a minimum.

5" Gauge Jubilee Range

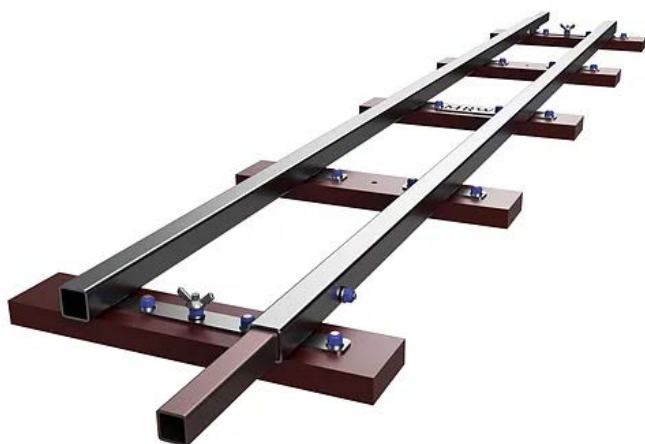

Straight Portable Jubilee Track Panel

1.49m. track panel, 1.71m with fishplate
 Dimensions: 298mm wide, 47mm tall
 Weight 6.8kg (approx)

5" Gauge Panel	SKU: STRT-5-1.5
----------------	-----------------

This is the 5 inch version of our popular 7¼ gauge Jubilee track panel. These panels share the same 25x25 box steel section and plastic wood sleepers as their larger 7¼ counterparts but are well proportioned to give a track panel that "looks

right" and gives adequate stability for passenger carriage.

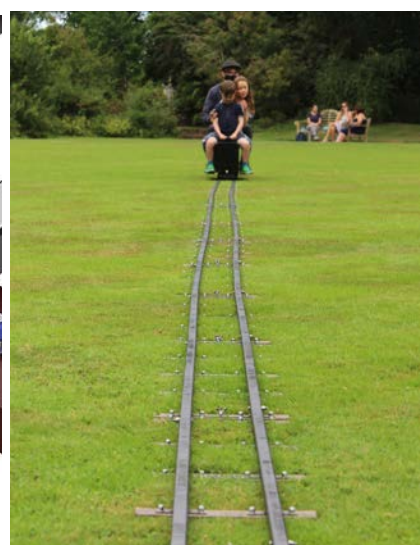
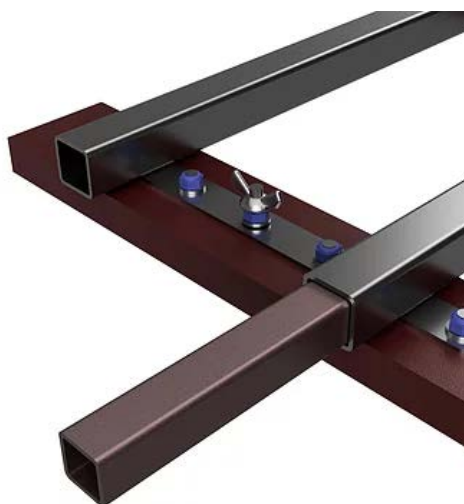
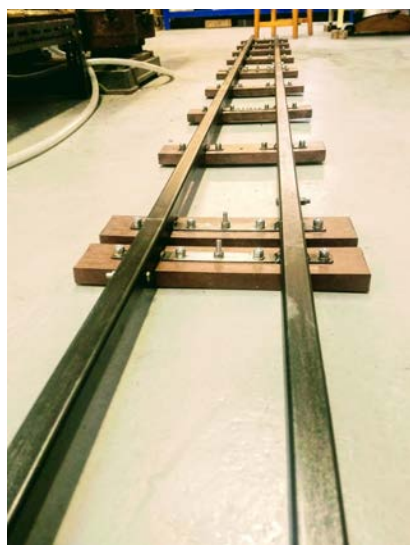

5 inch is well suited for back garden applications as the locomotives are smaller and easier to lift/handle. We recommend for most public and passenger carriage that 7 ¼ gauge will give better stability for safe operation of the railway.

(Q Radius) 5.6M [18' 6"] Radius Curve



Length 1.51m. track panel, 1.72m with fishplate
 Dimensions: 330mm wide, 47mm tall
 Weight 6.9kg (approx)

Complete circle / 360 degree loop:
 [24 x 15 degree sections]

U Bend / 180 degree turn:
 [12 x 15 degree sections]

Right angle / 90 degree turn:
 [6 x 15 degree sections]



5" Gauge Panel	SKU: CURVE-5-Q
----------------	----------------



This is an ideal panel for 5 inch gauge railways as most locomotives will run happily all day around this radius. As with all our track panels, these sections have been gauge widened and provided you are not using locos with unusually long wheelbases, they should be able to negotiate these curves without any issue at a normal running speed.

We first supplied these curves to a customer in the south of England and there is an excellent video of a train running round these curves here:

[Complete loop of track around a house using MRW portable track](#)

(V Radius) 3.88M [12' 9"] Radius Curve



Complete circle / 360 degree loop requires: [16 x 22.5 degree sections]

U Bend requires / 180 degree turn:[8 x 22.5 degree sections]

Right angle requires / 90 degree turn:[4 x 22.5 degree sections]

5" Gauge Panel	SKU: CURVE-5-V
----------------	----------------



This is the tightest radius of which most short wheel base locos or bogied locos can easily negotiate. Our portable points in 5 inch will be designed to this radius and passing loops will be possible as well as other more complex track plans.

As an approximation, we would suggest the maximum wheelbase for this track is up to 400mm, but if the centre wheel is flangeless or there is some side play in the middle axle, then you may be able to use longer wheelbase locos on this radius track.

We have supplied these curves to customers around the world but have a video here of them being tested right here in Nottingham: [Complete loop of track made from \(V Radius\) 5.6M \[18' 6" \] radius curve, with Neptune 3 on test.](#)

(V Radius) 5" Portable Jubilee Points

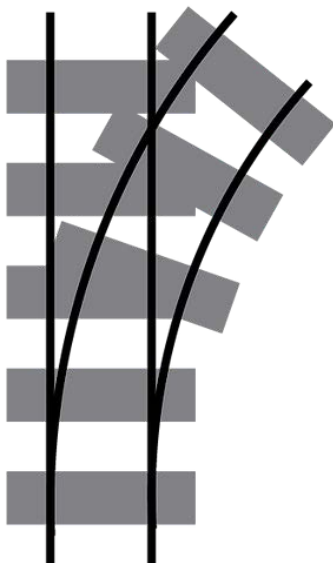

5" Portable Points	SKU: PNT-5-RH, PNT-5-LH
--------------------	-------------------------

To complement our standard curves, we also offer points in 5 inch gauge. These points are made as one piece unlike their 7¼" counterparts and are suitable for most 5 inch gauge locomotives.

Length 1.49m, Radius 5.6M [18' 6"] curve
 GL5 Standards
 Weight 10kg(approx)

We are accepting orders for our 5 inch points so drop us a message if you're interested in Left or Right Hand 5" Portable Points .

Buffer Stops 5" Gauge Portable Jubilee Track

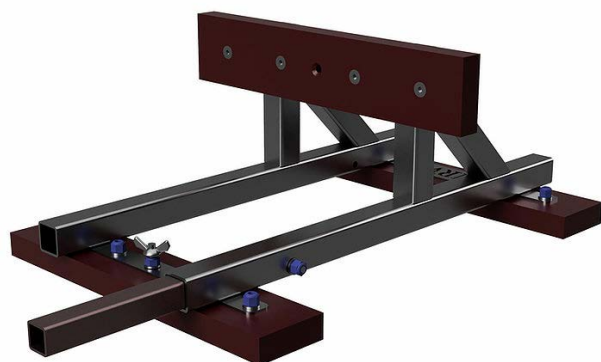

This narrow and standard gauge buffer stop which conforms with the GL5 Association standards.

Length : 0.43m. track panel, 0.54m with Fishplate
 Dimensions: 388mm wide, 177mm tall
 Weight 3.5kg (approx)



5" Gauge Buffer Stop	SKU: BUFF-5
----------------------	-------------

7¼” Gauge Jubilee Range



Straight Portable Jubilee Track Panel

1.49m. track panel, 1.71m with fishplate.

Dimensions: 370mm wide, 47mm tall

Weight 6.8kg (approx)

7 1/4” Gauge Straight Panel	SKU: STRT-7_1/4-1.5
-----------------------------	---------------------

As standard, all MRW Jubilee track panels are gauge widened by 2.3mm [3/32"]. This allows for curves to be joined to straights. This widening is within the 7¼ Gauge Society standards and should not adversely affect running.



The Jubilee Portable Track slots together very quickly which means an entire railway can be built in just minutes, providing a temporary back garden railway that can be laid, used and taken up again, all in one day, returning the garden to normal afterwards. Also, with MRW’s range of straights, points and curves, your track can be changed at will so you can construct a different layout design almost every time. Finally, if you or your club wish to attend the local fete then the Jubilee Portable Track is the ideal solution, being quick and easy to assemble.

We have a great video of the track being laid here:

[Build Your Own Miniature Railway In Just 3 Minutes](#)

Buffer Stops 7 ¼” Portable Jubilee Track



The narrow and standard gauge buffer stop conforms with the 7 ¼ Gauge Society standards.

Length 543.5mm Total Height 197.7mm
 Conforms with 7 ¼ gauge society standards
 Weight 3.5kg (approx)

7 1/4" Gauge Buffer Stop	SKU: BUFF-7_1/4
--------------------------	-----------------



The buffers are made from the same box steel used for the rails and are of sturdy construction to take the impact of a train at low speed.

Although we hope that you never need to use the buffer stops for the purpose of stopping a train, we have some recommendations in case it should happen.

A full explanation of how best to use the buffer stops is covered on Page 11 of the Operating Manual available for [download on the website](#)

Photo left: Patrick Allen GLMR



Above Diagram: Buffer stop connected to track panels with “Track Panel Tie Bar”.

Red arrows show force applied by the heavy impact of a train.
Blue arrows show the movement of the track panel at the joint.

2023 BROCHURE AND PRICE LIST

(A Radius) 15.2M [50ft] radius curve



Length 1.51m. track panel, 1.72m with fishplate
 Dimensions: 388mm wide, 47mm tall
 Weight 6.9kg (approx)

Complete circle / 360 degree loop:
 [64 x 5.6 degree sections]

U Bend / 180 degree turn:
 [32 x 5.6 degree sections]

Right angle / 90 degree turn:
 [16 x 5.6 degree sections]



7 1/4" Gauge Panel

SKU: CURVE-7_1/4-A



The (A) curve is our largest radius curve; it is designed to accommodate all locomotives in 7 1/4" gauge - even those with the longest wheel arrangements. This radius matches our points and allows for the quick design/laying of passing loops and sidings. The (A) curve when laid as a loop gives large sweeping curves ideal for passenger haulage and reliable running. If you are looking to run a commercial railway or regularly take passengers, this is the ideal curve to consider.

(K Radius) 9.4M [30.9ft] Radius Curve - Formerly (I Radius)



Length 1.4m. track panel, 1.61m with fishplate
 Dimensions: 388mm wide, 47mm tall
 Weight 6.9kg (approx)
 Two options of curve angle available 8.4 or 2.8



7 1/4" Gauge Panel	SKU: CURVE-7_1/4-K
--------------------	--------------------

Complete circle / 360 degree loop requires : [42 x 8.4 degree sections] + [2 x 2.8 degree sections]

U Bend requires / 180 degree turn: [21 x 8.4 degree sections] + [1 x 2.8 degree sections]

Right angle requires / 90 degree turn: [10 x 8.4 degree sections] + [2 x 2.8 degree sections]

Our (K) radius curve is nearly half the radius of our (A) curve. The (K) curve allows sharper turns, ideal for the smaller garden and similar confined spaces. We would not normally recommend a commercial operator to go any tighter than this radius. Tighter than 30ft in radius raises the likelihood of derailments and starts to increase and wear on rails. The (K) curve can be successfully used in conjunction with the (A) radius curve to build a very practical and usable passenger-carrying railway.

(O Radius) 7.06M [23.1ft] Radius Curve



Length 1.4m. track panel, 1.6m with fishplate
 Dimensions: 402mm wide, 47mm tall
 Weight 6.9kg (approx)

Complete circle / 360 degree loop:
 [32 x 11.25 degree sections]

U Bend / 180 degree turn:
 [16 x 11.25 degree sections]

Right angle / 90 degree turn:
 [8 x 11.25 degree sections]

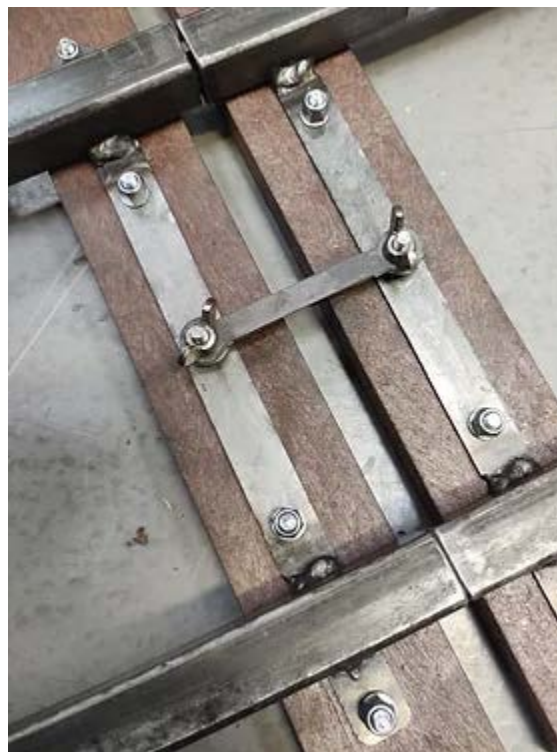

7 1/4" Gauge Panel	SKU: CURVE-7_1/4-O
--------------------	--------------------



The (O) radius curve is a tight radius curve that allows railways to be built in confined spaces and is a very handy radius when planning a railway to fit within specific limits. This curve is less than half the radius of our (A) radius and is really pushing the limits of what we recommend a commercial operator to be using for regular passenger carriage.

We would suggest that this curve is only laid on the flattest of surfaces if planned to take passengers. Special care must also be taken with the outer rail to ensure that the joints are not allowed to spread, which could lead to derailments.

(S Radius) 4.5M [14.8ft] Radius Curve



Length 1.45m. track panel, 1.63m with fishplate Dimensions: 0.4mm wide, 47mm tall
Weight 6.9kg (approx)

7 1/4" Gauge Panel

SKU: CURVE-7_1/4-S



Complete circle / 360 degree loop: [20 x 18 degree sections]
U Bend / 180 degree turn: [10 x 18 degree sections]
Right angle / 90 degree turn: [5 x 18 degree sections]

The (S) radius curve is less than a third of the (A) radius in size, measuring in at 4.5M [14.8ft] compared to a 15.2M [50ft] radius curve. This is a seriously tight curve that will happily fit inside many indoor settings or for use in a very confined garden. We think this is the absolute tightest that can realistically be achieved in this design of track and is best suited for very flat/firm ground where the track can be kept in good alignment.

We have used this radius for our open days and have supplied it to multiple customers. If you are looking for a railway to fit in a very tight space then this is the curve for you. Please note we do not generally recommend this curve for commercial running.

(A Radius) Points and Point Lever 7 ¼ Gauge Portable Jubilee Track



These points are 50 foot radius to match our (A) radius curves for use with both standard gauge and narrow gauge locos/rolling stock. The two halves of the points weigh 15kg and 17kg respectively making them an easy 1 person lift. By fitting the tie bar you can be sure that the panels stay locked together during use. Our points are best used with our portable point lever (see universal Jubilee products section).

Length 2.98m
 Conforms with 7 ¼ gauge society standards
 Weight 32kg (approx)

Left or Right Hand 7¼" Portable Points	SKU: PNT-7_1/4-RH, PNT-7_1/4-LH
---	---------------------------------------

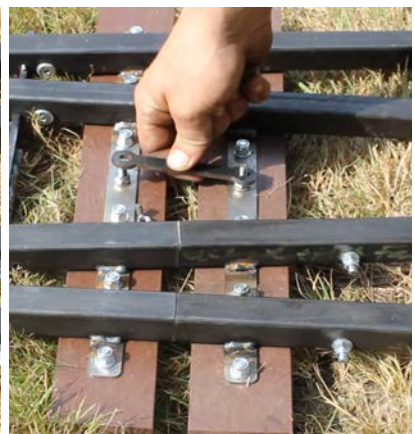

For more info on the [Point Lever - Fully Trailable](#) see product listing.

Loading Ramp For Jubilee Portable Track

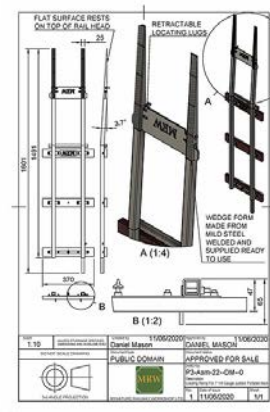

The loading ramp is designed to move locos and rolling stock on and off permanent tracks and onto Jubilee track sections. The ramp is made so that the wheels of the train can be rolled up the wedge shape and onto the box steel. The loading ramp then joins directly to standard Jubilee Portable Track sections.

1.49m. track panel, 1.6m with Fishplate
 Dimensions: 370mm wide, 47mm tall
 Weight: 9kg (approx)

7¼" Gauge SKU LOAD-RAMP-7.25	5" Gauge SKU LOAD-RAMP-5
---------------------------------	-----------------------------



The wedge is made of mild steel welded construction and supplied ready to use.

Alignment of the wedge shape is critical when using the ramp. It is necessary that the ramp is properly situated and aligned with the rails it is resting on. Full details about operation are shown in the [operating instructions](#).

Video: [Moving 7 1/4 inch gauge loco, unloading live steam miniature locomotives MRW portable track](#) - See on the MRW YouTube Channel

These products are normally kept in stock with no deposit required if ordering less than 30 sections in total.



Order more than 30 sections of track and receive a 5% discount!

To access this discount you will need to contact us for a direct quote.

To place an order you can either wait for products to be in stock on the website or contact us directly for a quote and we can then accept your order with a 25% deposit. When you pay the deposit we will then confirm the lead time on your order. To receive the 5% discount you must also accept to pay the 25% deposit when placing your order.

Email: miniaturerailwayworkshop@gmail.com

Tel: 07591 006642

Custom Radius Curved Jubilee Track Panels



We can produce curves in almost any radius and to any gauge. It is best for delivery and handling that a track panel is around 1.5m long. For this reason we will discuss with you the best trade off between section length and radius to achieve the curve you desire.

For all custom curves, you need to contact us directly for a quotation and can produce a technical drawing for the panel you have requested.

Every panel we make is produced in a custom made welding jig to ensure correct alignment of the components. This reduces manufacturing time which in turn passes savings on to you.

The cost for custom panels will be similar to the standard panel but there may be a surcharge due to the set up time required. This will be calculated at the time of quotation.

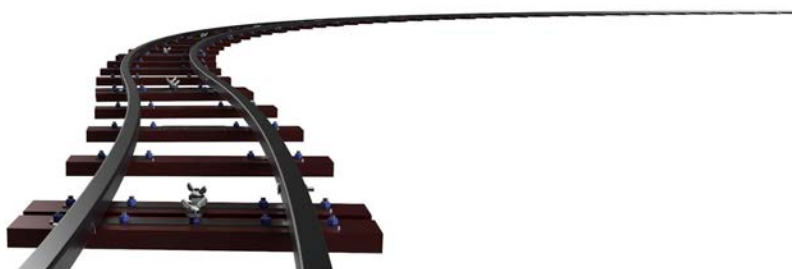

Other gauges - 7½” 3½” 10¼” & 15” Jubilee options

All of the Jubilee portable track shown in this brochure has been designed and manufactured right here by MRW in Nottingham. This means if we wish to adapt or change a design to suit a different gauge or specific customer requirements, we often can. Below are some examples of 3½”, 10¼” & 15” panels.

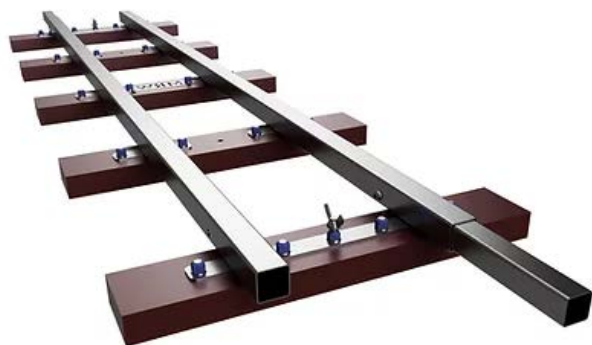

3 ½” Gauge Straight	POA
10 ¼” Gauge Straight	POA
10 ¼” Gauge Curve	POA
15” Gauge Straight	POA
15” Gauge Curve	POA

7 ½” Gauge Straight	POA
7 ½” Gauge Curve	POA

7 ½” Gauge Track Range

At MRW we have already exported 5” gauge track to North America and have designed 7 ½” gauge track. If you are interested in 7 ½” gauge track, please contact us directly to discuss further.

Multi Gauge Jubilee Track Panels; 10¼, 7¼, 5 & 3½

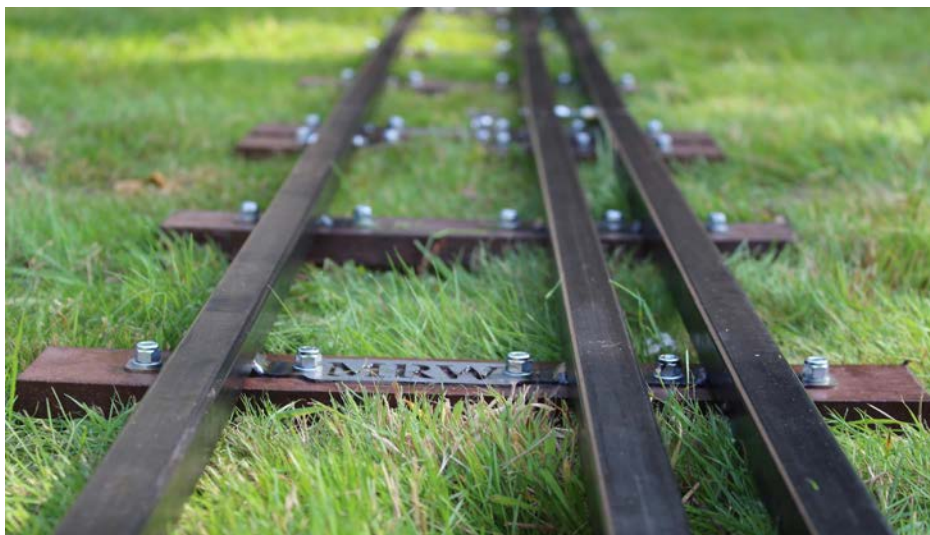

Triple and Dual Gauge Panels - 7¼", 5" and 3½" Straight Portable Jubilee Track Panel

1.49m. track panel, 1.71m with Fishplate
 Dimensions: 370mm wide, 47mm tall
 Weight: 9.5kg (triple), 8.2kg (dual)

7¼" & 5" & 3½" Gauge Panel	SKU: STRT-7_1/4-5-3_1/2-1.5
7¼" & 5" Gauge Panel	SKU: STRT-7_1/4-5-1.5



5 & 3.5" Straight Portable Jubilee Track Panel

1.49m. track panel, 1.71m with Fishplate
 Dimensions: 298mm wide, 47mm tall
 Weight 7.8kg (approx)

3½" Gauge Panel	SKU: STRT-5-3_1/2-1.5
-----------------	-----------------------

Universal Jubilee Track Components

These items can be used across most gauges and are interchangeable.

Track Panel Tie Bar

We recommended the use of our locking joining tie bar to hold track sections together, especially buffers and curves. They can be used with 7¼", 5" and dual gauge track sections.

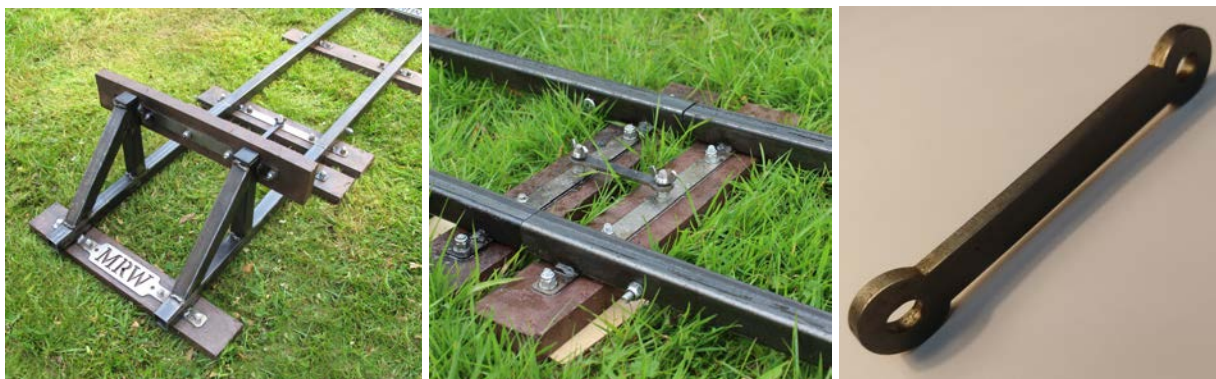

On straight sections of track the likelihood of sections becoming detached is very minimal and the tie bar really is not needed. On curves, points and buffer stops where trains may cause the track to separate, the tie bar is recommended to ensure your railway stays firmly connected.

Tie Bar	SKU:TRACK-P_TIE-BAR
---------	---------------------

Point Lever - Fully Trailable



The point lever attaches to the side of the portable points and is designed to be "fully trailable." This means a train can trail through the points when they are set against it without damaging the point blades or mechanism. The force to hold the blades in place can be adjusted by moving the weight up and down the lever. The whole point lever assembly can be attached to either side of the points within a minute.

Portable Point Lever	SKU: JUBILEE-POINT_LEVER
----------------------	--------------------------

Jubilee Rail Joiners

Want to join the Jubilee Track to Another Type or Rail?

We offer a range of options to join your Jubilee track to other portable rail types or to connect to a permanent railway. All of the joiners we have made so far have been straight but we can also make curved versions and custom sizes to suit your needs.

Permanent Joining Panel 5" & 7 1/4" Gauge Jubilee Portable Track

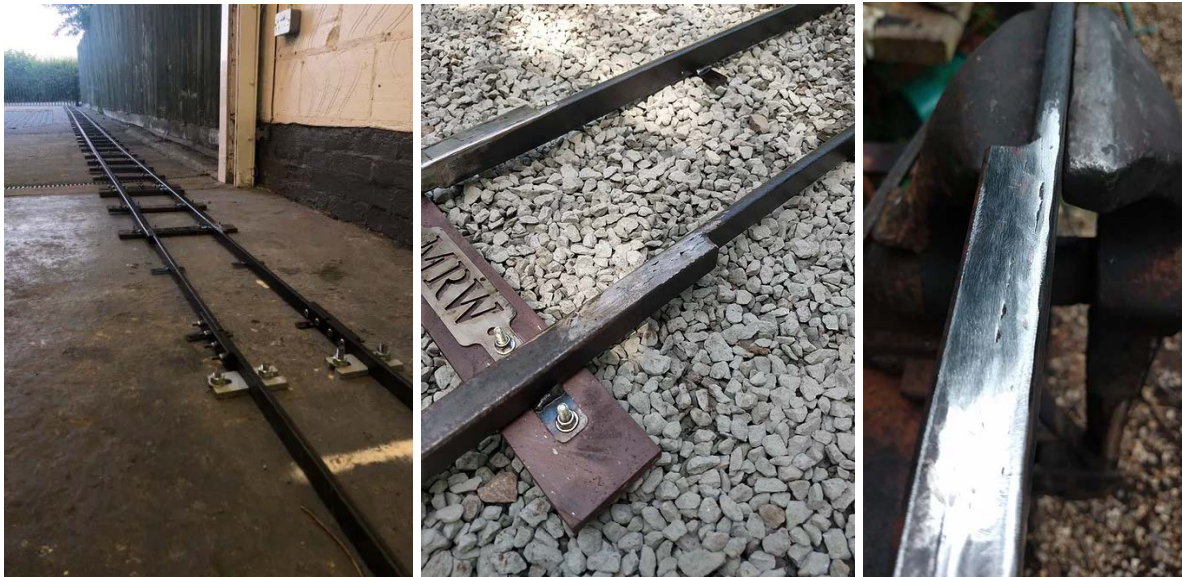

Left photo: Panel in situ sent to us by our happy customer.

We make custom track panels to join our Jubilee track to other rail types. The joining track panels are the same size as our standard straight section but with the rail changing midway to match that of your choice. *These products are made to order and are purchased with a 25% non refundable deposit.*

Permanent Joining Panel	7 1/4" + 5" SKU	7 1/4" Gauge SKU	5" Gauge SKU
Flat bar steel (20 x10) For other sizes please contact us	BAR-JOIN-7.25_5 POA	BAR-JOIN-7.25 POA	BAR-JOIN-5 POA

Semi-Permanent Joining Panel 5" & 7 ¼" Gauge Jubilee Portable Track



This product allows MRW portable Jubilee track to be joined to permanent track in a 'semi permanent' joint. Connect your MRW Jubilee Track Panel to your permanent railway with this product. This panel gives a smooth and reliable joint between profile rail, commonly used on permanent tracks. The profile rail is firmly clamped in place with locking plates and bolts. A hidden bolt under the rail allows for fine height adjustment. See the tech drawing on our website for more info.

1.49m. track panel, 1.6m with Fishplate
 Dimensions: 370mm wide, 47mm tall
 Weight: 8kg (approx)

Permanent Profile Joining Panel	7¼" + 5" SKU	7¼" Gauge SKU	5" Gauge SKU
16 & 21mm Profile rail	PR-JOIN-7.25-5	PR-JOIN-7.25	PR-JOIN-5

The Aluminium rail is clamped into position using the plates on each side and can be carefully aligned to ensure a smooth joint. Consideration has been given to the aluminium rail wearing and hence fine adjustment to the height of the rail can be set with a countersunk bolt hidden under the rail. This product is now designed to work with both 16mm and 21mm profile rail in one product (instructions will be provided with your purchase). These products are normally kept in stock with no deposit required if ordering less than 30 sections in total.

Yes, It Will Rust!

The track is designed to be lifted when not in use and stored inside to minimise rust, but we wanted to test how it would behave outside for a prolonged period. This section (pictured below) has been outside through the winter for 12 months. It has some surface rust but is still very usable.

However, we do recommend that you lift your MRW Jubilee track when not in use in order to prolong its working life.

On leaving MRW, the steel has been coated in grease to reduce surface rust during transportation. Grease is classed as a carcinogenic and the user should avoid contact with skin/eyes and ingestion.

We have chosen not to paint the rail as this would quickly wear away with the passage of trains. If you do feel keen enough to paint the steel work when you first buy some MRW Jubilee track, then you can detach the sleepers and give the steel a good coating in paint.

Please remember if your track does pick up some surface rust, this should be monitored by the operator to ensure that this rust does not become excessive and impair the structural integrity of the track panel. For more info on the use of the track take a look at the [operating instructions](#)



Our products get better with age and use.

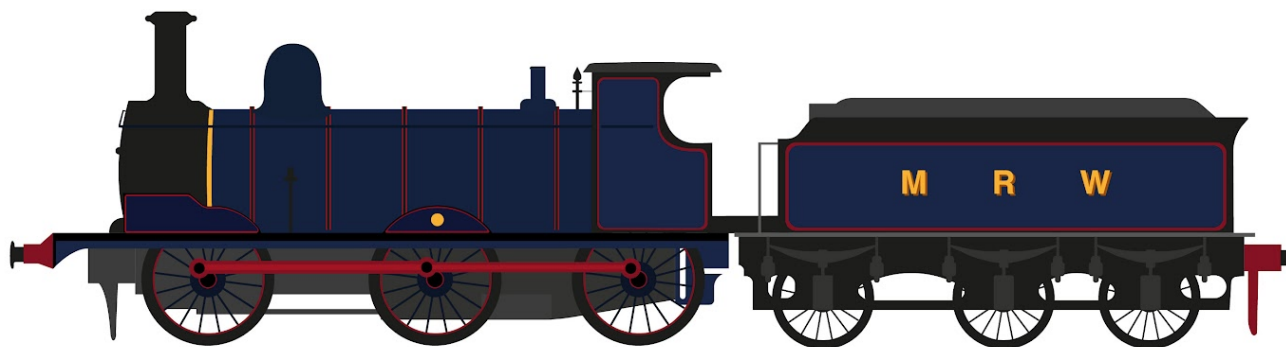

Just like a fine locomotive, our track gets better with age and use. Our products are designed to be used regularly and give reliable service.

Thanks to [Alex Skelton](#) for producing this artwork. Copyright MRW 2021

Starter Packs of Jubilee Track



NEPTUNE STARTER SET



9.3M [30' 6"]

7.8M [25' 6"]

x2 x16

5" MINIATURE RAILWAY LOOP SET

Neptune 5" Miniature Railway Starter Set - V Radius Loop, Loco and Coach

A complete starter set to create your own miniature railway with a ready to lay loop of 5" Gauge 3.88M / 12'9" portable track complete with two standard straight sections, alongside a Neptune locomotive and driving truck.

2023 BROCHURE AND PRICE LIST

Our (V) radius curve is a very tight radius curve and is designed for temporary use in back gardens and confined areas where space is at a premium. These panels allow you to build a railway in almost any confined space with ease. We would not recommend these curves for regular commercial/public railways as there is an increased risk of derailments with this tight radius - use in these environments is purely at the operator's discretion. They are however ideal for a back garden setup or even for use inside with family and friends.



Package Contents

5" Gauge Curve (V Radius)	CURVE-5-V	x 16 off
5" Gauge Straight	STRT-5-1.5	x 2 off
Track Panel Tie Bar	TRACK-P_TIE-BAR	x 18 off
Locomotive Ready-to-Run Neptune (3)	5-NEP-3	x 1 off
Couplings Bar and Pins		x 1 set
5ft Riding Truck Ready-to-Run vinyl wrapped riding truck	DRIVE-TRUCK-5FT-5	x 1 off

Neptune Starter Set (V Radius Loop, Loco and Coach)

SKU: 5-NEP3-SS

Optional Extras

Diesel Engine Sound System (Optional extra)	-SS	x 1 off
Side Cranks and Rods (Optional extra, pictured in red)	-CR	x 1 set

The 5% discount is applied to optional extras if ordered with the above package.



NEPTUNE STARTER SET



Neptune 7 1/4" Miniature Railway Starter Set - S Radius Loop, Loco and Coach

A complete starter set to create your own miniature railway with a ready to lay loop of 7 1/4" Gauge 4.5M / 14'9" portable track complete with two standard straight sections, alongside a Neptune locomotive and driving truck.

Our (S) radius curve is a very tight radius curve and is designed for temporary use in back gardens and confined areas where space is at a premium. These panels allow you to build a railway in almost any confined space with ease. We would not recommend these curves for regular commercial/public

2023 BROCHURE AND PRICE LIST

railways as there is an increased risk of derailments with this tight radius - use in these environments is purely at the operator's discretion. They are however ideal for a back garden setup or even for use inside with family and friends.



Package Contents

7 ¼" Gauge Curve (S Radius)	CURVE-7_1/4-S	x 20 off
7 ¼" Gauge Straight	SRT-7_1/4-1.5	x 2 off
Track Panel Tie Bar	TRACK-P_TIE-BAR	x 18 off
Locomotive Ready-to-Run Neptune (3)	7_1/4-NEP-3	x 1 off
Couplings Bar and Pins		x 1 set
5ft Riding Truck Ready-to-Run vinyl wrapped riding truck	DRIVE-TRUCK-5FT-7.25	x 1 off

Neptune Starter Set (S Radius Loop, Loco and Coach)

SKU: 7_1/4-NEP3-SS

Optional Extras

Diesel Engine Sound System (Optional extra)	-SS	x 1 off
Side Cranks and Rods (Optional extra, pictured in red)	-CR	x 1 set

The 5% discount is applied to optional extras if ordered with the above package.

"Click and Play" Track Range Straights Points and Curves

We are pleased to formally announce that the Colin Edmondson range of "Click and Play" track will now be available at MRW as a ready-to-lay product.

This is a unique product designed by Colin a number of years ago and has been well proven. The track is constructed from flat bar steel with a number of laser cut components. It is a very light weight and extremely portable design which has a standard radius of just 2M. 'This



is ideal for the small four wheeled locomotives which Colin has already designed, such as the Scamp and Imp, which are available for purchase through CMD Engineering. The tightness of the curves allow the track to be laid in even the smallest gardens and yards; with plenty of room for sidings, passing loops etc.

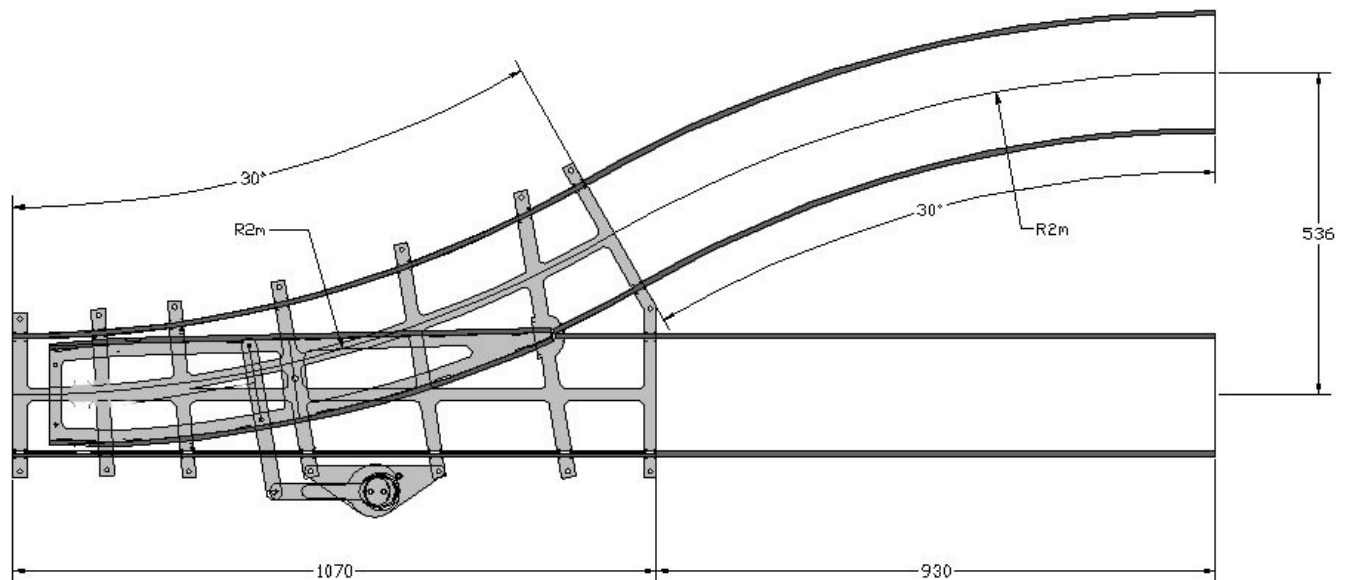

The track is only designed to be suitable for laying on flat surfaces such as indoor, tarmac or hard packed earth. It has not been tested or approved for use as a portable railway on soft grass. This product is not suitable for commercial use and is not suggested for regular passenger carriage. If you are looking for a portable track solution for regular public carriage, we would recommend looking at our Jubilee Portable Track range.

2023 BROCHURE AND PRICE LIST

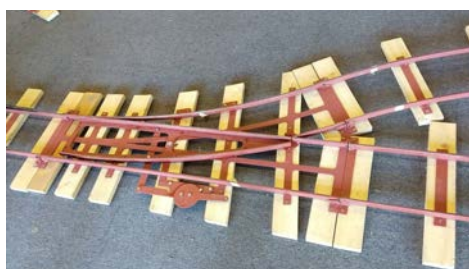

Currently the range includes; straights, curves and left hand or right hand points. We will be working over the coming months to expand the information on the website and take further photos of the products in use, but in the meantime please contact us for more information and to place an order.

Buffer Stops

Future development of buffer stops is planned for the “Click and Play” track range - please contact us for details.

7¼" Gauge	Painted with Sleepers	Un-Painted without Sleepers
Straight	ST-C/P	ST-C/P-NS
Short Straight (for points)	SST-C/P	SST-C/P-NS
Curve	CV-C/P	CV-C/P-NS
Points (RH or LH)	PNT-LH-C/P PNT-RH-C/P	PNT-LH-C/P-NS PNT-RH-C/P-NS

The track panels are supplied as either **painted with sleepers** or **unpainted without sleepers options**.

Our Guarantee

We use our in-house designed and manufactured jigs to ensure the precise alignment of every section, but if you should have any problems we ask that you contact us and we will be happy to help.

The track is always test-assembled in our workshop prior to dispatch to ensure the alignment and fitment are satisfactory and we will often run a wagon over it to ensure we are happy with every single section before dispatch.



Semi-Permanent and Permanent Track Products

Semi-Permanent track can be left out all year round without significant long term issues developing regarding its structural integrity. It can be lifted in a matter of hours rather than days. The definition between portable, semi-permanent and permanent can be blurred and a track system such as our Jubilee track can and has been laid in a permanent manner. That said, the product ranges outlined below are far better suited than Jubilee track for semi-permanent or permanent use.

Britannia Semi-Permanent Track Range



The Britannia range is designed to be a semi-permanent flat-bar rail solution that can be laid either with or without ballast, but not requiring any rail rolling or welding on the part of the builder. The track has been designed to function as a completely ready to lay range complete with fishplates specifically designed for flat bar. The range includes; Straights, Curves of various sizes, Points and buffer stops. Non-standard products can also be manufactured upon request such as crossovers and special form points.

The Britannia track range is manufactured here at MRW by our team and we are confident that it will satisfy the needs of many miniature railway enthusiasts with a quick to lay product that can be taken up and changed in configuration as the desire may take them.

The track range is available in two rail forms, either 30x12mm or 20x10mm flat bar steel. In addition, MRW are also able to supply 2M flat bar lengths in either size off the shelf along with the required fishplates/chairs for you to build custom panels for yourself or use the PNP chairs as you may wish to construct special panels to fit your specific needs. The track is not as rigid as our Jubilee range hence should be only laid on a very level base and appropriate ballast/support used to ensure the track is level and firm.

2023 BROCHURE AND PRICE LIST

1.9M Straight Britannia Medium Duty Track Panel



Supplied as a ready to lay, pre drilled track section either with or without plastic wood sleepers. This is an ideal candidate for semi-permanent railways where the track may need to be

lifted when moving house or simply changing the design of the railway. Medium duty Britannia track uses 20x10mm flat bar steel as a rail. Britannia panels are long lasting with their solid bar rail construction.

Sleepers	7¼" Gauge	5" Gauge
Without Sleepers	ST-BRT-M/D-7.25-1.9-NS	ST-BRT-M/D-5-1.9-NS
20x60mm Plas. Wood	ST-BRT-M/D-7.25-1.9-20	ST-BRT-M/D-5-1.9-20
30x60mm Plas. Wood	ST-BRT-M/D-7.25-1.9-30	N/A

Curved Britannia Medium Duty Track Panel

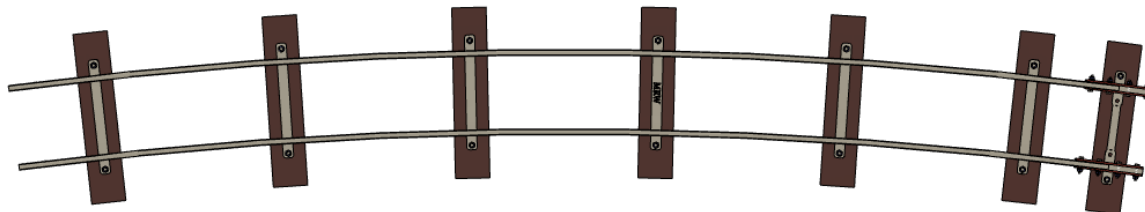

Supplied as a ready to lay, pre drilled, pre rolled, track section either with or without plastic wood sleepers. No hassle required to roll the sections as they come pre-rolled and ready to lay. The track is designed to be lifted and taken up semi-regularly, so the panel will hold its shape when removed from ballast. A variety of radiuses will be available ranging from 50ft down to 14.8ft.

Radius Options:

(C Radius) 14.7M [48" - 2'] Panels to complete right angle: 12, panels to complete right angle: 24.
(O Radius) 7.4.7M [24" - 1'] Panels to complete right angle: 6, panels to complete right angle: 12.

Sleepers	SKU Prefix	7¼" Gauge SKU	5" Gauge SKU Suffix
Without 20x60mm Plastic Wood 30x60mm Plastic Wood	C-, O-	CURVE-BRIT-M/D-7.25-NS CURVE-BRIT-M/D-7.25-20 CURVE-BRIT-M/D-7.25-30	C-CURVE-BRIT-M/D-5-NS C-CURVE-BRIT-M/D-5-20 C-CURVE-BRIT-M/D-5-30

1.9M 7 ¼” Heavy Duty Track Panel Straight and Curve



Just as the medium duty range, the heavy duty range is supplied as a ready to lay, pre-drilled track system, either with or without plastic wood sleepers. The heavy duty range is designed to take up to tinkerbell type narrow gauge 7 ¼” locomotives with an evenly distributed mass of up to 600kg. Using heavy duty 30x12mm flat bar and 30mm deep, extra wide sleepers, the heavy duty range is designed to be a long lasting track system for the enthusiast. This track is again an ideal candidate for semi-permanent railways where the track may need to be lifted when moving house or simply changing the design of the railway.

Sleepers	7¼” Gauge
Without Sleepers	ST-BRT-H/D-7.25-1.9-NS
30x60mm Plas. Wood	ST-BRT-H/D-7.25-1.9-30

1.9M Curved Britannia 7 ¼” Heavy Duty Track Panel



Supplied as a ready to lay, pre drilled, pre rolled, track section either with or without plastic wood sleepers. The heavy duty range is designed to take up to tinkerbell type narrow gauge 7 ¼” locomotives with an evenly distributed mass of up to 600kg. Using heavy duty 30x12mm flat bar and 30mm deep, extra wide sleepers, the heavy duty range is designed to be a long lasting track system for the enthusiast. Current radius options are (C Radius) 14.7M [48” - 2’], (O Radius) 7.4.7M [24” -1’].

Sleepers	SKU Prefix	7¼” Gauge SKU
Without	C-, O-	CURVE-BRIT-H/D-7.25-NS
30x60mm Plastic Wood		CURVE-BRIT-H/D-7.25-30

2023 BROCHURE AND PRICE LIST

Flat Bar Points - Left or Right Hand (Incl. Heavy Duty)



A heavy duty ready to lay set of points that have been designed with many of the key features of our existing portable points from the Jubilee range included. These points feature the same interchangeable component design as our portable range

and are proven to trail very well in the example pictured above. They are currently available in (C Radius) 14.7M [48" - 2'] and (O Radius) 7.4.7M [24" - 1'].

Sleepers	SKU Prefix	7¼" Gauge SKU Suffix (or RH)	5" Gauge SKU Suffix (or RH)
Without 20x60mm Plas. Wood 30x60mm Plas. Wood Without (H/D) 30x60mm Plas. Wood (H/D)	C-, O-	PNT-LH-BRIT-M/D-7.25-NS PNT-LH-BRIT-M/D-7.25-20 PNT-LH-BRIT-M/D-7.25-30 PNT-LH-BRIT-H/D-7.25-NS PNT-LH-BRIT-H/D-7.25-30	PNT-LH-BRIT-M/D-5-NS PNT-LH-BRIT-M/D-5-20 PNT-LH-BRIT-M/D-5-30 Not Available Not Available

Flat Bar Combi Fishplates

Sold complete with required bolts ready to install, these are suitable for 10x20 flat bar. These fishplates are unique for flat bar as they support rail to combat dipping on the joints while being completely free of any need to use a welder.



Gauge	SKU
5" Gauge 5" Gauge 10 Pack 7¼" Gauge 7¼" Gauge 10 Pack	COMBI-FISH-5 COMBI-FISH-5-PACK COMBI-FISH-71/4 COMBI-FISH-71/4-PACK

Bender for Flat Bar Rail

Rail benders suitable for 25x10mm & 30x12mm bar stock. **This is a new product for us and is available upon request.**

25 x 10 Flat Bar Roller	25/10-FB-BENDER
30 x 12 Flat Bar Roller	30/12-FB-BENDER

2023 BROCHURE

PNP Bar Rail Chair (12mm x 30mm Rail)

Bulk discounts apply for 300+ Chairs

This rail chair has been designed to accept readily available 12mm x 30mm bar rail. The Chair is designed to gently grip the flat bar and is an ideal choice for permanent railways. If you wish to create a dual gauge line, a packer (PNR-12L) can be placed in the chair so that the smaller 10mm x 20mm bar rail can be used for the third line. The chair has been designed to be used either with PNP plastic 7¼" Narrow Gauge sleepers (PNR-12i) or wooden sleepers. If used with PNP sleepers, automatic gauge widening is built in.



Bar Rail Chair (12mm x 30mm Rail)	SKU: PNR-12K
-----------------------------------	--------------

PNP Bar Rail Chair Packer for 5" Gauge Line – to suit 10mm x 20mm Bar Rail

These packers will allow you to lay a 5" gauge line in the smaller 10mm x 20mm bar rail alongside the 7¼" line using the larger bar rail chair and 10mm x 30mm bar rail. To be used either with PNP sleeper (PNR-12i) or wooden sleepers.



Bar Rail Chair Packer (12mm x 30mm Rail)	SKU: PNR-12L
---	--------------



PNR-5A
With lug on bottom for
PNP Sleeper



PNR-5B
Smooth bottom for all
other sleepers

PNP Bar Rail Chair

The bar rail chair is a generic chair manufactured in a strong engineering plastic. The chair attaches to the sleeper with 2 screws. Designed to suit 10mm x 20mm bar rail. The chair suits all standard scale sleepers in the PNP Railways range.

PNP Flat Bar Rail Chair (10mm x 20mm Rail)	SKU: PNR-5A SKU: PNR-5B
---	----------------------------

Permanent Profile Rail Products

Profile rail is an excellent choice for permanent railways. It mimics the shape of rail used on full size narrow gauge and mainline railways and works best in terms of the wheel interaction with the rail. Profile rail must be laid with excellent groundwork and maintenance should be kept on top of to ensure safe and reliable running. Profile rail can often be good value per money per metre, but requires a keen eye and good knowledge of railways to be laid correctly. If done so, it looks by far the most convincing compared to the railways of years gone by.

Profile Rail products - 10m Garden Track Kit

For a permanent railway, profile rail is the ideal solution; it behaves and looks like real rail and allows for complex railways to be built with ease. Sold with 5/8" x 5/8" (16mm) Aluminium Rail 2.5m Length.

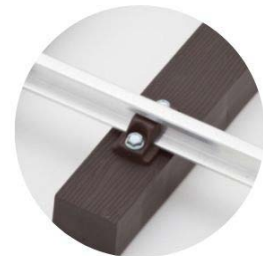

Screw Fit Chair



Clip Fit Chair

Gauge	Screw Fit	Clip Fit
3½" Gauge 10m (32ft)	SKU: PNR-10B	SKU: PNR-9Z
3½" & 5" Gauge 10m (32ft)	SKU: PNR-5R	SKU: PNR-8C
5" Gauge 10m (32ft)	SKU: PNR-5S	SKU: PNR-8B
5 & 7 ¼" Gauge 10m (32ft)	SKU: PNR-6K	SKU: PNR-8E
7¼" Gauge 10m (32ft)	SKU: PNR-6J	SKU: PNR-8D

Price shown is per 10m (32ft) of track complete with fishplates and required sleepers, chairs and rail.

2023 BROCHURE

Standard Scale PNP Sleepers - Bulk discounts apply for 300+

PNP Produce a range of plastic injection moulded sleepers complete with correct holes for either screws or clip fit chairs. These are available in various gauges outlined below.



Gauge	Screw/Clip Fit
3½"	SKU: PNR-9K
5"	SKU: PNR-1T-C
5" & 3½"	SKU: PNR-1T-A
7¼"	SKU: PNR-1T-H
7¼" & 5"	SKU: PNR-1T-G

A slightly over scale sleeper that is designed for stability when passenger hauling. Although not of any particular scale, it is highly suited for both standard and narrow gauge locomotives and rolling stock. The sleepers are injection moulded from high grade engineering polymers, making them extremely durable, rot, frost and UV resistant.

The system is very quick and easy to assemble - no drilling is required as the sleepers are moulded with pilot holes for the screws/clips, with automatic gauge widening built-in. They have hollow ribbed undersides to allow the ballast to enter, making an extremely stable base.

Narrow Gauge PNP Sleeper

The largest sleeper in the PNP range, this sleeper has been designed to carry the weight of the larger and heavier locomotives and rolling stock which are becoming very common in 7¼" gauge. This sleeper can be used in conjunction with a wide range of steel and aluminium profile rail.

Dimensions – L 460mm x W 75mm x D 55mm

7¼" & 5" Dual Narrow Gauge Sleeper **Screw Fit Only**	SKU: PNR-12I
--	--------------



2023 BROCHURE AND PRICE LIST

5/8" x 5/8" (16mm) Aluminium Rail

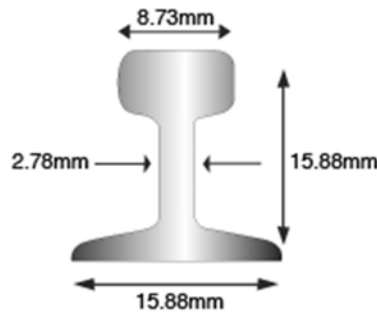

Suitable for 3½", 5" & 7¼" Standard Scale club or garden railways.

Supplied in 2.5m lengths, therefore when ordering please order the total number of 2.5m lengths required, not metres.

Rail Material Specification – The aluminium alloy is type 6082 tempered to T6
Weight 0.7kg (approx) per 2.5m length

5/8" x 5/8" (16mm) Aluminium Rail 2.5m length	SKU: 16MM-ALURAIL
--	-------------------

PLEASE NOTE:- rail is supplied as section only. Fishplate holes are to be drilled by the customer

Fish plates for 16mm & 21mm Aluminium Rail - **Bulk discounts for 11+**



PNR 2F LIGHT



PNR 3K HEAVY

Fish Plates - Light (4plates 8 bolts/nuts)	SKU: PNR-2F
Fish Plates - Heavy (4plates 8 bolts/nuts)	SKU: PNR-3K

It is down to personal preference and what you will be running on your track. From our experience running 7¼" gauge railways we would only use the heavy duty versions as these have proven to be much easier to remove after years of use.

Screw Fit - Rail Chairs for Standard Gauge Sleepers/Rail

For use with PNP sleepers or Plastic Wood Sleepers supplied by MRW see [Plastic wood](#) product page.



Rail Chair for 16mm Rail For PNP Plastic Sleepers	SKU: PNR-1T-B **
Rail Chair to suit 16mm Rail For Wooden Sleepers	SKU: PNR-1T-D
Rail Chair to suit 21mm Rail For PNP Plastic Sleepers	SKU: PNR-2G **
Rail Chair to suit 21mm Rail For Wooden Sleepers	SKU: PNR-3N

**Chairs are designed to work with the PNP sleepers, they include a spigot that protrudes below the chair and clips inside a hole in the PNP sleeper, hence maintaining gauge. The chairs described as being suitable for wooden sleepers do not have this spigot protruding from the bottom. They can be mounted on wooden or plastic wood sleepers, the gauge will need to be checked manually.

Clip Fit - Rail Chairs for Standard Gauge Sleepers/Rail

An easy to assemble design where you just slide the chair onto the rail, locate the spigot into the sleeper and push down. Automatic gauge widening built in if used with the PNP moulded plastic sleepers.

Rail Chair (Clip Fit) Suitable for use with PNP Sleepers and 16mm Rail	SKU: PNR-7Y
---	-------------

Please note that this chair is only suitable for use with the "Standard Gauge" PNP sleepers and not the Narrow gauge version.

Please note this chair is not suitable for use with wooden or Plastic Wood Sleepers.



2023 BROCHURE AND PRICE LIST

Screws – Pack of 100

Suitable for most PNP chairs/sleepers these are 3/4" head, 8g hex washer self tapping screws suitable for wooden and plastic sleepers.



Screws – Pack of 100

SKU:
PNR-1T-E



Bender for Profile Rail

Rail benders suitable for 16 and 21mm aluminium or steel rail, and 27-31mm aluminium or steel rail respectively. Simply wind the handle to add a curve to the rail. The bender features lugs to hold it firmly in a vice. Its 6mm steel construction means it is sturdy and will perform well with the specified rail types.

Rail Bender 16-21mm Profile Rail

16/21-P-BENDER

Rail Bender 27-31mm Profile Rail

27/31-P-BENDER



Plastic Wood Products

Plastic Wood

Plastic wood is a long lasting solution for sleepers, it drills and cuts like wood and has a similar weight. It is an ideal choice for portable railways as well as permanent. This is a realistic and sustainable alternative to traditional hardwood sleepers. It doesn't need preserving prior to installation and is **100% recycled and fully recyclable.**



Plastic Wood

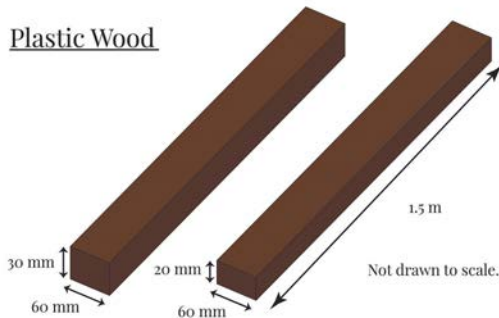

Dimensions 20mm x 60mm x 1500mm (1.5m)
 Weight 1.70kg per 1.5m length.
 Each 1.5m length when cut will give four 7 ¼ gauge sleepers.
Minimum order of 5 lengths

20x60x1500mm	SKU: PW-20X60
30x60x1400mm	SKU: PW-30X60



Large Plastic Wood

Price per length 50x120x1400mm	SKU: PW-50X120
-----------------------------------	----------------

Length of solid plastic wood suitable to be cut into large gauge miniature railway sleepers such as 10 1/4" or 15" gauge railways.
 50x120x1400mm (1.4M)
 Weight 8kg (approx) per 1.4m length.
Minimum order of 4 lengths

2023 BROCHURE AND PRICE LIST

MRW Pre-Cut Sleepers

Plastic wood is a long lasting solution for sleepers and MRW recommend this material for all situations where sleepers are required to support rails. We recommend two profiles; 20x60mm for 5" and medium duty 7 1/4" use and 30x60mm for heavy duty 7 1/4" use. For locos weighing over 200kg total, we would strongly encourage the heavy duty sleeper as this is an excellent starting point for medium to large sized steam locos and more commercial focussed internal combustion or battery electric locos. We offer the following pre-cut sizes:-

Gauge	Dimensions	SKU
5"	20x60x298mm	5-SLEEPER-20X60MM
7 1/4"	20x60x370mm	7_1/4-SLEEPER-20X60MM
7 1/4" Heavy Duty	30x60x395mm	7_1/4-SLEEPER-30X60MM

Edging Strip and Stakes



Edge Strip 7 x 140mm x 10m

Weight 12kg per 10m roll.

Stakes for Edging 380mm Long (Pack of 10)

Weight 2.5kg per 10 stakes.

Stakes 380mm long (Pack of 10)	SKU: STAKE-10-PACK
Edge Strip 7mmx140mmx10m	SKU: EDGE-STRIP



Turntables

We offer a range of portable, semi-permanent and permanent turntables to suit your needs, this is a relatively new product range for MRW and one which is rapidly expanding. If you can't find the type of turntable you require then please do make contact to discuss further.

Scamp and Short Wheelbase Rolling Stock Drop-On Turntables

The Scamp and Short Wheelbase Rolling Stock Drop-On Turntables were conceived originally for the Scamp by its revered designer Colin Edmondson, but are equally useful for short wheelbase locos and rolling stock. MRW are delighted to be manufacturing this product in partnership with Colin right here in our Nottinghamshire workshop.

The turntables are based on historic portable turntables used for manual shunting on narrow gauge temporary railways. They are extremely versatile and can be placed almost anywhere on a track, allowing locos and rolling stock to be turned in any direction to be moved onto another line, or even simply back in the direction they came. The turntables can also be used as a low cost alternative to a set of points where applicable, making them an excellent tool at the disposal of anyone with a desire to break up rolling stock, load locos and wagons as a one man operation, or simply have fun with their Scamp on a running day!



5" Drop-On Turntable	7 ¼" Drop-On Turntable	7 ¼" Heavy Duty Drop-On Turntable
800L x 240W x 50H mm Maximum Wheelbase of Outer Wheelsets: 390mm (15.25")	800L x 285W x 50H mm Maximum Wheelbase of Outer Wheelsets: 390mm (15.25")	1300L x 285W x 50H mm Maximum Wheelbase of Outer Wheelsets: 540mm (21.25")
SKU: SCAMP-TURN-5-MD	SKU: SCAMP-TURN-7.25-MD	SKU: SCAMP-TURN-7.25-HD

2023 BROCHURE AND PRICE LIST

7 ¼” Four Way Drop on Turntable

A brand new product from Colin Edmondson which has been developed 2021/2022 we plan to offer this for sale in 2023.

The main base is flat bottomed so you can add sleepers if you wish, the ramps just hook into place and have lugs to locate within the rails to hold it all in place. Just drop the deck on and it's ready to use. The rails on the deck are about 22mm above the running rails, so it's a gentle ramp. There are carrying handles to make it easy to move. There are adaptors to suit 16mm alloy rail if you want to build it in permanently, and also adaptors to join up with the 'click and play' portable track system.



7¼” Four way drop on turntable (Does not include joiners)	4-WAY-DROP-ON-TURNTABLE-7.25
Ramped Joiners	4_WAY_DROP_ON_TURN-7.25-RAMP
Click & Play Joiners	4_WAY_DROP_ON_TURN-7.25-C&P
16mm Rail Joiners	4_WAY_DROP_ON_TURN-7.25-16MM

7 ¼” Commercial Grade Semi-Permanent Turntable

An in-house designed Turntable cable of turning some of the largest locos and rolling stock in 5” and 7¼”. Designed to be semi-permanent with the ability to install the turntable in a matter of hours depending on ground surface. We plan to release this product for general sale in 2023 please make contact with us if this is a product that interests you and we can discuss placing an order.

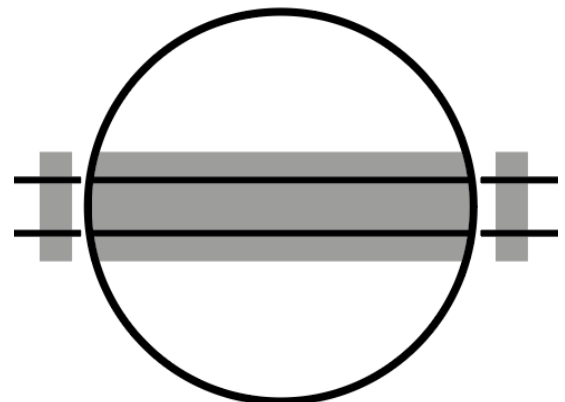

Semi-Permanent Turntable	Gauge
	VIC-TURN-5, VIC-TURN-7.25
	VIC-TURN-7.25-5

Locomotive Moving Products

At MRW we regularly move locos and rolling stock for delivery, events and running days. With locomotives in 7 ¼" gauge weighing anywhere up to 500kg, moving them in a safe manner is a challenging task. That said, MRW are excited to design products to meet this challenge and offer high quality, robust and reliable methods to aid loco transportation. All these products are currently on an enquiry basis only, but do check our website for updates from the time of print at www.miniaturerailwayworkshop.com.

Car/Van/Trailer Transporter Track Panels

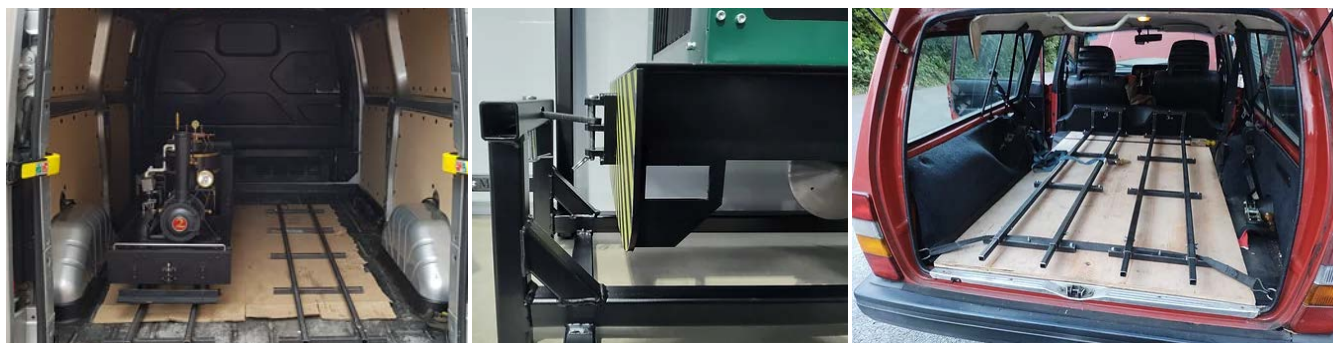

Offered in a range of sizes these panels can be bolted down into the vehicle to aid in holding down locomotives and rolling stock. Offered in both 5" and 7 ¼" gauge as individual gauges or dual gauge, the products come in a range of standard sizes; 1M [3'-3"], 1.25M [4'-1"], 1.5M [4'-11"], 1.75M [5'-9"], 2M [6'-7"], 2.25M [7'-5"], 2.5M [8'-2"]. All panels are powder coated as standard. The product range is split into two main devices: Transporter Track Panels and Loading Bridges (see separate product listing).

The products need to be used alongside ratchet straps/chains/clamps which are not provided by MRW; the emphasis is for the user to move miniature locomotives safely. These products are an aid to a market where no off-the-shelf existing transporting products exist but are not a complete solution; it is down to you as the user/operator to ensure they are used safely.

Gauge	SKU
5"	CVT-5-
7 ¼"	CVT-7_1/4-
5" + 7 ¼"	CVT-7_1/4+5-

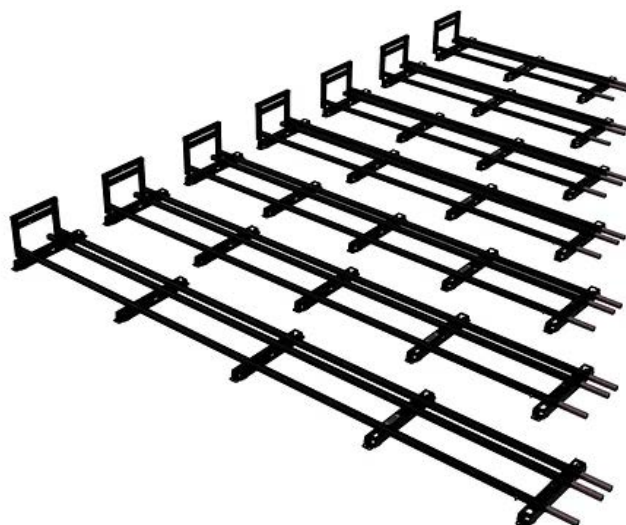

2023 BROCHURE AND PRICE LIST

Loading Bridge

As an addition to the transporter panels, we offer two lengths of bridge that allow locos and stock to be loaded into vehicles and onto our transporter panels. They are also excellent tools for spanning short gaps, such as onto hydraulic lifting tables for example. The bridges are available in 5", 7 1/4" and dual gauge and in 0.58M and 1.25M lengths.



Gauge	SKU
5"	LB-5-
7 1/4"	LB-7_1/4+5-
5" + 7 1/4"	LB-7_1/4-

Loading Ramp Bracket Kit

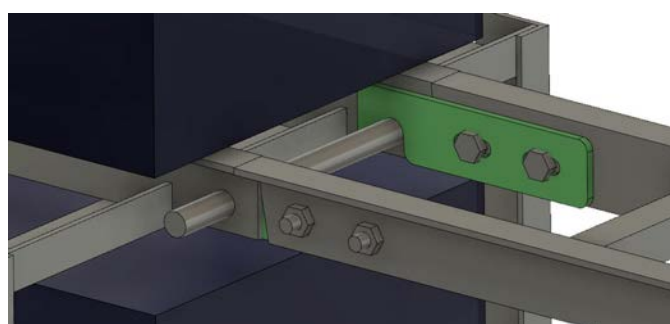

MRW have used this design of bracket for loading ramps, trolleys and in front of the storage container at Top Field Light Railway (above). The hook form means that they can pivot slightly making joints more accommodating of changes in height. We have used the brackets with 30x60x5mm unequal steel angle, although we leave this up to you to decide what you wish to mount the brackets onto. Suitable for 7 1/4" and 5" gauge. Bracket size: 200mm x 50mm 6mm laser cut mild steel.

Brackets only	RAMP-BRACKET
Brackets, Nuts/Bolts and Steel Bar	RAMP-BRACKET-KIT

Workshop Trolley

A simple to use Loco moving trolley to help you move rolling stock and locos around the workshop for maintenance and storage. The trolleys are at the correct height for comfortable working and can be built for any gauge or length of loco. **Please note - we are currently finalising the design of this product and it will look somewhat different from the example image (right).** The product will be available in the following lengths; 1m, 1.25m, 1.5m, 1.75m, 2m, 2.25m and 2.5m.



Workshop Trolley	WORK-TROL
------------------	-----------

'Off-Road' Loco Moving Trolley

The 'off-road' loco moving trolley is designed to allow the easy transportation of locomotives from sheds to trailers, trailers to gardens, and anything in between.

By 'off-road,' we mean the trolley is suitable for garden paths and uneven ground (within reason) at your local club. The trolley will be available in a range of lengths, from 1 metre long rails to 2, and is supplied in both 5 and dual 7¼" & 5" gauge as standard. The trolley has front end steering and is low to the ground, making it stable and manoeuvrable.



Off-Road Loco Moving Trolley	OFF-ROAD-TROL
------------------------------	---------------

Rolling Stock

Rolling stock is the key to keeping things moving. Whether you're pottering around in the garden, taking in scenic views at your local club or shunting just like in the sidings of days gone by, we're delighted to offer a growing range of products to suit a variety of budgets, offered in partnership with Abbots Model Engineering and revered miniature railways designer Colin Edmondson.

MRW 7 1/4" Principle Wagon Ready-To-Run



A simple, tried and tested design with a completely wooden chassis, plain bearings running in oilable axleboxes, and hook and chain couplings for the full dumb buffer bumping effect! These charming wagons will be available in a number of body styles, from flat wagon to box van, and are as much a useful working wagon as they are an item of rolling stock to create an inexpensive train at an affordable price. Made from hardwood and built in the UK, the wagons are robust enough to be used for moving heavy objects and their minimal style means they suit minimal, narrow gauge and some small standard gauge locos.

Body Style	SKU	Description
Flat Wagon	7_1/4-FLAT-WAGON	Basic flat wagon
3 Plank Wagon	7_1/4-3-PLANK-WAGON	Basic wagon with short sides
5 Plank Wagon	7_1/4-5-PLANK-WAGON	Basic wagon with medium sides
7 Plank Wagon	7_1/4-7-PLANK-WAGON	Basic wagon with tall sides
Box Van	7_1/4-3-BOX-VAN-WAGON	Basic wagon box van

2023 BROCHURE

5" / 7 ¼" GUV/SK/BSK Driving Trucks, 3ft,4ft,5ft



The GUV/SK/BSK coach supplied by MRW is designed to be a working coach and hence has printed details and a sturdy build quality. The design is well proven and has been developed from a range of similar coaches built by Abbots Engineering. Every coach uses a rapid fit running board system that requires no nuts, bolts or tools to attach. This helps with easier storage and transportation of your truck, not to mention quicker set-up for a day's running

Material: CNC laser cut steel and welded providing a sturdy body that will reliably carry your passengers. Finish: Metal parts of the coach are powder coated black whilst liveries are printed on vinyl. The driving trucks are available in 3ft, 4ft and 5ft lengths, with handbrake cable operated braking on one or both bogies, and vacuum braking as another additional option. Safety end guards are also available at a very affordable price.

Type	SKU Prefix	SKU Suffix
GUV-, BSK-, SK-	DRIVE-TRUCK-	3FT, 4FT, 5FT



2023 BROCHURE AND PRICE LIST

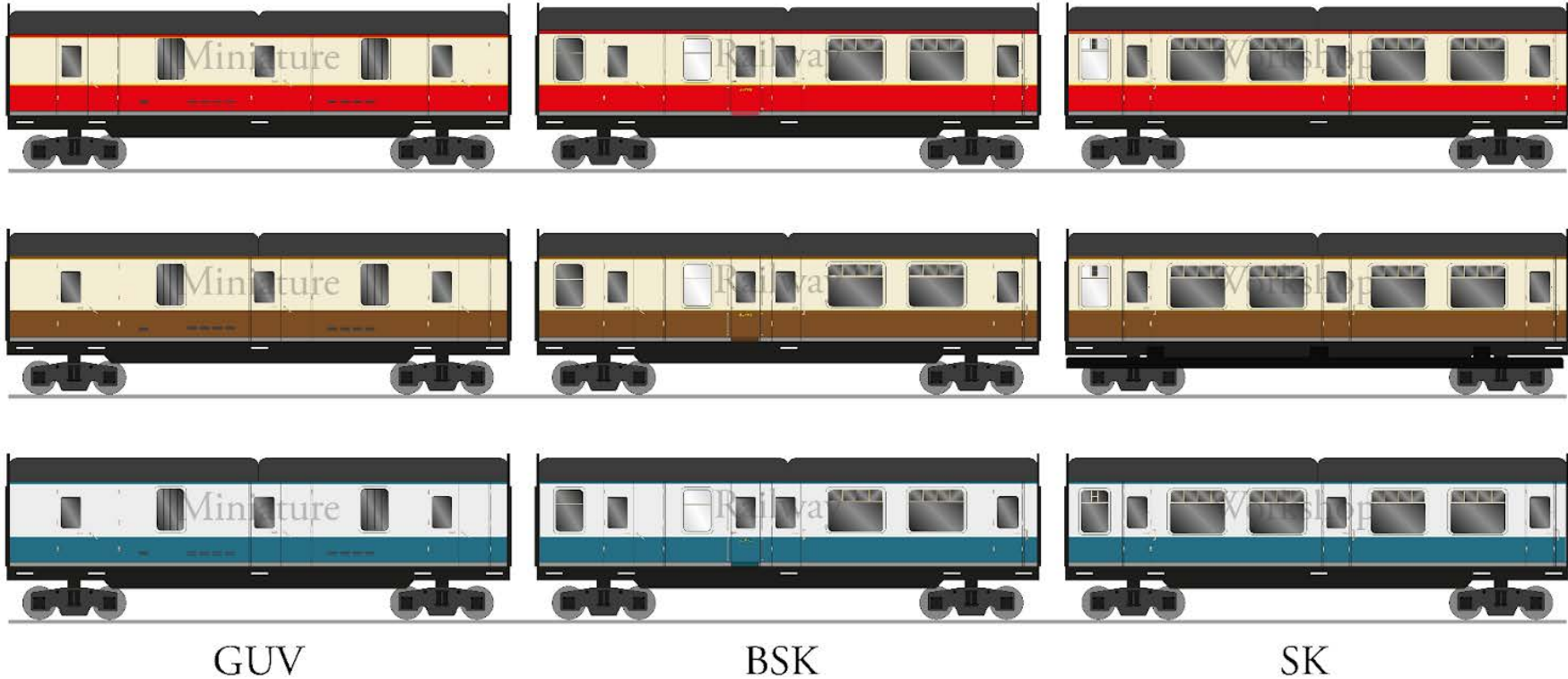

GUV (General Utility Van) A barred window vehicle generally used for parcels and goods traffic.

BSK (Braked Standard Corridor) A coach including a guard's compartment and passenger seating

SK (Standard Corridor) A conventional corridor coach.

2023 BROCHURE

7 1/4" Commercial Ground Level Sit-Astride Passenger Coach



Ready to run coaches which are suitable for club track, portable events or a large garden railway. The coaches feature an all steel construction utilising laser cut components and CNC turned wheelsets to achieve a consistent product where components are interchangeable and highly reliable.

Built to order on a short turnaround, these coaches can be painted in a variety of colours with the parts professionally powder coated before assembly. Measuring 2.2M long, 5 adults can happily sit on the coach with space to spare. The footboards are wide enough to hold even the largest boot without worry of feet sliding off the footrest, or coming into contact with lineside features.

A reliable club coach that has been developed from years of knowledge and experience gained in building locomotives and rolling stock. Built by Abbots Model Engineering in Telford, these coaches have successfully and reliably run at many clubs and private railways around the world. These are a well proven design that can hold up to regular use at both the club or home track.

Commercial Sit-Astride Passenger Coach	SKU	Add Vacuum Braking
Square End	COM-COACH-SE	-VB
A Shaped End	COM-COACH-AE	-VB



2023 BROCHURE AND PRICE LIST

7 1/4" / 5" Ready-To-Run Bogies for Miniature Trains



A reliable bogie set that has been used on many carriages and riding trucks for over a decade at clubs and private railways around the world. These are a well proven design that can hold up to regular use at both the club or home track and represent excellent value for money. Built by Abbots Model Engineering in Telford, these bogies have been used in countless riding trucks and are still fitted as standard after many years.

7 1/4" Technical Information:

Length: 31cm, Total Height: 12cm, Center pivot shaft diameter 12.7mm (1/2"), Weight: 8.5kg (approx per bogie), Wheel diameter: 88.0mm(3.5") - contact point of wheel not overall diameter

5" Technical Information:

Length: 23cm, Total Height: 11cm, Center pivot shaft diameter 12.7mm (1/2"), Weight: 4.2kg (approx, unbraked), Wheel diameter: 67mm(2 5/8" approx.) - contact point of wheel not overall diameter.

Gauge (Sold in Pairs)	Standard	Single Braked Bogie	Two Braked Bogies
5"	5-BOGIE-PAIR	-SB	-TB
7 1/4"	7.25-BOGIE-PAIR	-SB	-TB

Colour Options

Locomotives and coaches can be supplied in a range of colours to the customer's specification. The image supplied (right) shows the range of colours available at the powder coater's and these include such examples as BR Blue. For further information please contact us about colours for locomotives and rolling stock.



Edmondson 7 ¼” Commercial Sit-Astride Passenger Coach & Bogie



Colin Edmondson designed, MRW manufactured. These high quality articulated sit astride coaches are tried and tested by both permanent and portable railways across the country. Their monocoque sheet metal chassis makes them lightweight for their size and therefore well optimised for carrying as many passengers as possible. The benefit of this is that the locomotive does not have to work as hard pulling heavy coaches, maximising passenger carrying ability. Available in 5ft, 6ft, 7ft, 8ft and 9ft lengths, these coaches are capable of comfortably taking up to 7 adults or even more children in the full length model!

Built to order on a short turnaround, these coaches can be painted in a variety of colours with the parts professionally powder coated before assembly. The coaches come with stainless bolts and high grip tape on the running boards, whilst the Zintec steel body can be used in all weather conditions as any quality commercial coach should. We have personally run these coaches throughout a month of December British weather, taking thousands of passengers. We experienced no issues, and no derailments, which is a testament to their proven design; Colin first completed the design in 2014 and the coaches come with a pedigree of regular commercial use up and down the country.

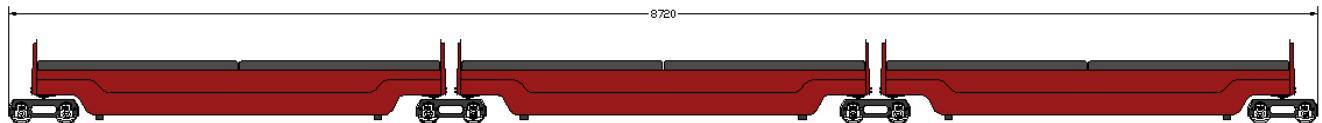

The coaches are articulated, so share their heavy bogies between coaches. This design characteristic coupled with the sheer weight of the bogies means they are exceedingly difficult to derail. They feature semi-independent suspension and 6” diameter wheels, making for a smooth ride even on poor lines. The bogies are available unbraked, or with compressed air braking (vacuum is a work in progress, please enquire). These are excellent bogies for other commercial and heavy duty DIY purposes and can be purchased separately.

Product	SKU Prefix	SKU Suffix	Braking Suffix
Coach	ECC-	5FT, 6FT, 7FT, 8FT, 9FT	-BRK
Bogie	CB-	N/A	NB, VB, AB

Locomotives



Locomotives are what give the hobby its foundation. Whether you're firing your favourite replica steam engine, shunting wagons in the garden with a Scamp or pulling passenger coaches at the club with your Neptune 4, the trains are what bring us all together and we're delighted to show off our line-up of locos and sold in partnership with Abbots Model Engineering in Telford.



5" / 7 1/4" / 7 1/2" Neptune (2) Ready-To-Run 0-4-0 Loco



A ready to run loco with all paint and electronics completed ready to run on your home track or club. The Neptune 2 is a steel body shunter loco which is small enough to fit inside a small car, meaning it is perfect for a day out at the local club. A reliable locomotive that has been used on miniature railways around the world, designed from years of knowledge and experience gained from building locomotives and rolling stock. Built by Abbots Model Engineering in Telford, these locomotives have successfully and reliably run at many clubs and private railways around the world.

The locomotive has been proven to be able to pull 5 adults with ease (this is subject to gradient and rail head conditions). Both axles are individually powered with their own motor hence the Neptune (2) has 2 motors, one on each axle. Simply add batteries and enjoy a loco which looks great and works perfectly. These are a well proven design that can hold up to regular use at both the club or home track. Neptune (2) locomotives are available with optional sprung buffers, and a diesel engine sound system.

Neptune (2)	SKU
5" Gauge	5-NEP-2
7 1/4" Gauge	7_1/4-NEP-2
7 1/2" Gauge	7_1/2-NEP-2



Paint scheme refer to colour options in 'Rolling Stock'

2023 BROCHURE AND PRICE LIST

5" / 7 1/4" / 7 1/2" Neptune (3) Ready-To-Run 0-6-0 Loco



A ready to run loco with all paint and electronics completed ready to run on your home track or club. The Neptune 3 is a steel body shunter loco which is small enough to fit inside a small car but powerful, meaning it is perfect for a day out at the local club. A reliable locomotive that has been used on miniature railways around the world, designed from years of knowledge and experience gained from building locomotives and rolling stock. Built by Abbots Model Engineering in Telford, these locomotives have successfully and reliably run at many clubs and private railways around the world.

The locomotive has been proven to be able to pull 8 adults or more with ease (this is subject to gradient and rail head conditions). Each axle is individually powered with its own motor hence the Neptune (3) has 3 motors, one on each axle. Simply add batteries and enjoy a loco which looks great and works perfectly. These are a well proven design that can hold up to regular use at both the club or home track. Neptune (3) locomotives are available with optional sprung buffers, side cranks and a diesel engine sound system.

Neptune (3)	SKU
5" Gauge	5-NEP-3
7 1/4" Gauge	7_1/4-NEP-3
7 1/2" Gauge	7_1/2-NEP-3



Paint scheme refer to colour options in 'Rolling Stock'

2023 BROCHURE

5" / 7 1/4" / 7 1/2" Neptune (4) Ready-To-Run 'Bo-Bo' Bogie Loco



The Neptune 4 is a ready to run loco with all paint and electronics completed ready to run on your home track or club. The loco is a steel bodied mainline freight/passenger loco which is powerful yet versatile due to its four axle bogie design, meaning it is perfect for medium to heavy passenger pulling duties at clubs or for moving freight and supplies where required. A reliable locomotive that has been used on miniature railways around the world, designed from years of knowledge and experience gained from building locomotives and rolling stock. Built by Abbots Model Engineering in Telford, these locomotives have successfully and reliably run at many clubs and private railways around the world.

The locomotive has been proven to be able to pull 15 adults or more with ease (this is subject to gradient and rail head conditions). Each axle is individually powered with its own motor hence the Neptune (4) has 4 motors, one on each axle. Simply add batteries and enjoy a loco which looks great and works perfectly. These are a well proven design that can hold up to regular use at both the club or home track. Options include sprung buffers and a diesel engine sound system.

Neptune (4)	SKU
5" Gauge	5-NEP-4
7 1/4" Gauge	7_1/4-NEP-4
7 1/2" Gauge	7_1/2-NEP-4



Paint scheme refer to colour options in 'Rolling Stock'

Couplings and Braking



MRW supplies a range of couplings In stock and ready to dispatch. Our coupling bars suit all sizes of miniature trains from 3 1/2" gauge up to 10 1/4". Please note that we aim to dispatch these items the next day. If purchased with a long lead time product, we will hold this item and dispatch as one order-unless otherwise agreed.

Plain Coupling Pins

A coupling pin with retaining clip suitable for miniature ride on railways. These pins are ideal for use with both passenger and goods trains where you want a strong reliable joint between rolling stock and locos. These pins are zinc plated mild steel.

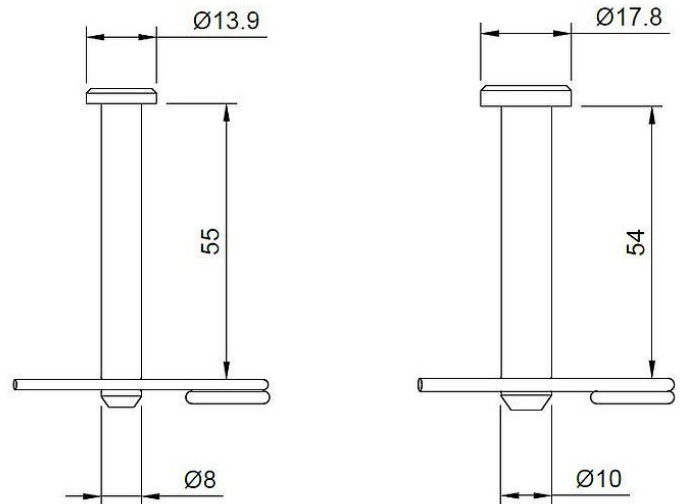

	8mm Diameter	10mm Diameter	12mm Diameter
1 off	PLN-PINS-8MM-X1	PLN-PINS-10MM-X1	PLN-PINS-12MM-X1
8 off	PLN-PINS-8MM-X8	PLN-PINS-10MM-X8	PLN-PINS-12MM-X8

Coupling Bars

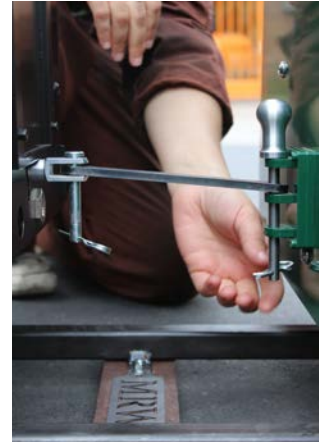

Left & Right Photos: Supplied by customer in use at home railway

Medium duty 9mm Hole Mild Steel Coupling Bars

Hole size is cut at 9mm diameter for use with a 8mm pin - 6mm thick mild steel

Heavy duty 11mm Hole Mild Steel Coupling Bars

Hole size is cut at 11mm diameter for use with a 10mm pin - 8mm thick mild steel

Super heavy duty 13mm Hole Mild Steel Coupling Bars

Hole size is cut at 13mm diameter for use with a 12mm pin - 10mm thick mild steel

	Medium Duty M/D-COUPLING-	Heavy Duty H/D-COUPLING-	Super Heavy Duty SH/D-COUPLING-
Hole centre spacing	Price and availability	Price and availability	Price and availability
60mm	✓	X	X
80mm	✓	X	X
100mm	✓	✓	✓
140mm	✓	✓	X
150mm	X	X	✓
160mm	X	✓	X
180mm	✓	✓	X
200mm	X	✓	X
300mm	X	X	✓

2023 BROCHURE AND PRICE LIST

Weld Free Coupling Block Range

Our updated coupling block range is now much broader and offers an improved array of options for all budgets! These popular weld free kits come as an unpainted set of parts to make a simple but very effective coupling for bar couplings. The assembly is bolted to the buffer beam of the loco/coach/wagon of your choice and this holds the assembly together. It can then be painted for appropriate appearance. These couplings tie in with our range of bars and pins to create a full system suitable for 5" to 10 ¼" use.

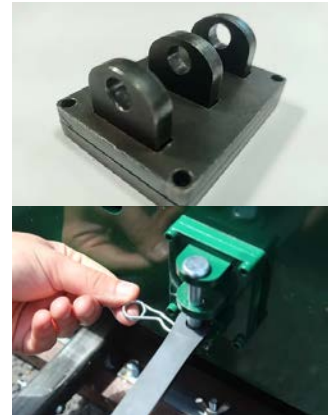

Type	One Slot SKU	Two Slot SKU
Medium duty 8mm pin	COUPLING-8MM-O/S	COUPLING-8MM-T/S
Heavy duty 10mm pin	COUPLING-10MM-O/S	COUPLING-10MM-T/S
Super heavy duty 12mm pin	COUPLING-12MM-O/S	COUPLING-12MM-T/S

Bar & Pin - Colin E. Chopper Large Head Coupling



Chopper couplings are common around the world especially on narrow gauge railways but they have not been widely adopted in the miniature railway hobby as they are not cross compatible with other coupling types without complex adaptors. These couplings designed by Colin Edmondson look like chopper couplings and hence complete

Kit	SKU: Chop-KIT(PAIR)
Single Assembled	SKU: Chop-Assem(SING)
Pair Assembled	SKU: Chop-Assem(PAIR)



Adaptor Plate For Couplings



This is a product our customers requested and is a safe method of coupling standard gauge hook and buffers to narrow gauge style slot and pin couplings. Many clubs run with multiple coupling types hence a method of coupling these two common types comes in handy. Product is designed to accommodate a 10mm pin although will work with a 8mm pin. Material: mild steel - mig welded construction, and fully painted in black paint.

Small 310mm Wide	COUPLING-ADAPTOR-310MM
Large 430mm Wide	COUPLING-ADAPTOR-430MM

Note: no pins or chain are supplied with this adaptor plate.

Large Scale Couplings

Large scale heavy duty mild steel coupling bars and pins suitable for miniature ride on railways. The coupling bar hole size is cut at 21mm for use with a 20mm pin, the holes centres of the bar are 300mm.



Large Scale Coupling Bar	LARGE-COUPLING-BAR-300MM
Large Scale Coupling Pin	PLN-PINS-20MM



Vacuum Release Valve

The valve will allow atmospheric air pressure into the vacuum reservoir to release the brakes on a detached vehicle. The brakes will come off, as the air pressure equalises each side of the diaphragm. Before this device is used it should be established that the vehicle in question can not roll out of control.

Vacuum Release Valve	SKU: PNR-1G
----------------------	-------------

2023 BROCHURE AND PRICE LIST

PNP Vacuum Reservoir Kit

The reservoir is a necessary component when fitting vacuum brakes. The reserve of vacuum (if there is such a thing) makes it possible to create the differential between it and atmospheric pressure to apply a force on the diaphragm, thus applying the brakes. The reservoir kit includes two prototypical-moulded ends, a length of plastic tubing and a sturdy purpose made strap and mounting clip. To assemble simply insert the moulded ends and glue with a suitable adhesive such as araldite. This kit includes:- 1 x Length of Tube, 1 x Bracket and Clip, 2 x End Caps.



Vacuum Reservoir Kit	SKU: PNR-1C
----------------------	-------------

Vacuum Brake Actuation Kit



PNP Railways vacuum brake actuation kits are available in two types, one with a stud extending from the rear cover and the other with two bearings mounted around its mid point. The actuator is powerful and reliable when working at the vacuum levels employed on most miniature railways. Fitting instructions provided with product and measurements available on the MRW website. We also supply the PNP refurbishment kit to suit PNP PNR-1A and PNR-2D vacuum brake actuation kits. The kit includes everything you need to service one PNR-1A or PNR-2D vacuum brake actuator.

Type	SKU
Standard	PNR-1A
Trunnion Mount	PNR-2D
Vacuum Brake Refurbishment Kit	PNR-12H

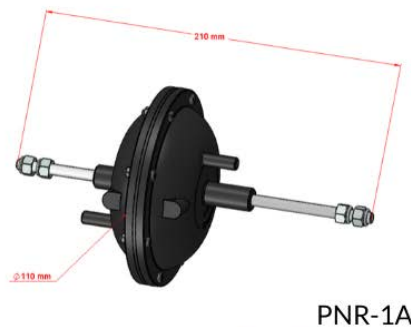

2023 BROCHURE

PNP Brake Blocks

Brake Blocks; 7¼" Standard Scale & 7¼" Narrow Gauge. PNP brake blocks are injection moulded in a grade of nylon which is filled with glass beads to a level of 40%. These beads are very small and provide the braking medium with the plastic acting as a carrier. The blocks are supplied as a set of 4, ready to fit, only requiring the pin hole to be drilled.



7¼" Standard Scale (4 Undrilled Blocks)	SKU: PNR 1D
7¼" Narrow Gauge (4 Undrilled Blocks)	SKU: PNR 1E

7 1/4" Gauge Reversible Wheel Scotch



The reversible wheel scotch is an excellent addition to the equipment at the disposal of operators. With reversible end plates to suit 5 and 6 inch diameter wheels, the scotches affords a simple, quick and effective method of arresting a locomotive or rolling stock. Locating tabs aid the alignment of the product with the rails, whilst the handle makes removal straightforward.

A minimum height of 38mm is required from the locomotive/rolling stock chassis to the railhead, so please check derailing bars, clearances and obstructions before making a purchase. Whilst this is a very useful tool, it should always be used in conjunction with a handbrake when available, therefore it is not designed or alludes to being a replacement for one.

Designed by Tim Rice of Rice Rail and manufactured, we're delighted to add this useful product to our range of tools.

7 1/4" Wheel Scotch	SKU: 7-25-SCOTCH
---------------------	------------------

2023 BROCHURE AND PRICE LIST

6mm ID 12mm OD Reinforced Hose (185A)

6mm ID 12mm OD Reinforced Hose (185A) - Sold Per Metre. Manufactured by Alfagomma in Italy, this is a high quality hose which is ideal for miniature train braking systems. We recommend this hose is used at couplings as it holds its form well and is a very sturdy hose.



- Tube: black synthetic elastomer - oil mist resistant.
- Reinforcement: high tensile textile cords.
- Constant operation: -10 °C +60 °C (+14 °F +140 °F)
- ID: 6mm (¼ in) - OD: 12mm (0.47 in) - Minimum Bend Radius: 48mm (1.89 in)
- Maximum Working Pressure: 20 bar (300 psi) exceeds DIN 20018/1

6mm ID 12mm OD Reinforced Hose (185A)

COUPLING-HOSE-12MM-OD



Ear Clips

We use these ear clips on our hose assemblies. They are very simple and effective - the ears have rounded edges which are perfect for hoses to be handled regularly.

Ear Clip

11-13MM-EAR-CLIP

Oetiker Compound Action Pincer Clamp

This is a high quality tool that correctly clamps the Ear Clip for installation.



Compound - Action Pincer

OETIKER-PINCER-CLAMP

Mini Ball Valve 1/8"

Male and Female 1/8" BSP thread ball valve.



Mini Ball Valve 1/8"

MINI-BALL-VALVE-1/8

2023 BROCHURE

Vacuum Hose and Fittings

A jumper hose complete with quick release couplings on each end already crimped on with stainless steel ear clips. These quick release couplings are perfect for miniature railway vacuum & air systems. They are compact enough to not look out of place on most miniature rolling stock, whilst still being large enough to be easily attached and detached even when wearing gloves.



Unlike most air fittings, these have been specially designed to **not shut off** when disconnected, meaning if the fitting becomes disconnected the brakes will actually be applied. Normal air fittings have an internal valve which means the brakes may not be applied in the scenario of a train separation. With other connectors, your brakes may not actually be fail safe.

Unvalved - 21 Series Quick Release Coupling



Male only - 1/8" Male Nipple	1/8"-MALE-NIPPLE
Female Only	1/8"-FEMALE-NIPPLE
Male and Female	1/8"-MALE/FEMALE-NIPPLE

This is a standard 21 series female quick release coupling but without the stop valve, meaning it lets air in or out when disconnected from its male counterpart.



Hose Tail

This is a standard fitting with a 1/8" barbed fitting and a Male 1/8" BSP thread.

1/8" x 1/8" Male Hose Tail	1/8X1/8-MALE-H OSE-TAIL
----------------------------	----------------------------

2023 BROCHURE AND PRICE LIST

M16 Adaptor

An Adaptor also referred to as a Bulkhead fitting allows you to mount the 21 series fittings in the end of coaches or rolling stock to ensure that fittings are securely positioned at the end of the vehicle.



1/8" BSP x M16 x 1.5 Adaptor	M16-BULKHEAD-A DAPTOR
---------------------------------	--------------------------



An Elbow fitting of 90 degrees with a male and female fitting both of 1/8" BSP thread size.

1/8" Elbow	1/8-ELBOW
------------	-----------



Vacuum & Air Coupling Hose; With Rolling Stock Fittings

One hose with female crimped hoses, 2 x 1/8" bsp - 1/8" Male Hose Tails, 2 x 1/8" bsp - M16 x 1.5 Adaptor, 2 x 1/8" bsp Elbow, 2 x 1/8" bsp Male Nipple

Vacuum & Air Coupling Hose

This product listing is for the hose with female fittings only, the male fittings are available separately.

Length of Hose	Hose With Female Fittings Crimped On Only	Hose With Female Fittings and Rolling stock Male fittings Included
30cm	SKU: JUMP-HOSE-30	SKU: TAIL+JUMP-HOSE-30
40cm	SKU: JUMP-HOSE-40	SKU: TAIL+JUMP-HOSE-40
50cm	SKU: JUMP-HOSE-50	SKU: TAIL+JUMP-HOSE-50
60cm	SKU: JUMP-HOSE-60	SKU: TAIL+JUMP-HOSE-60

Miniature & Full Size Steam Accessories and Supplies

Hurricane Steam Raising Blower



The MRW Hurricane steam raising blower is the perfect companion for a day's steaming, whether it be at home, at your club or at organised events. Designed to be the solution to underperforming, undersized and unsupported blowers, the Hurricane is handmade by us right here in Nottinghamshire, UK and suitable for a large 5" and medium sized 7 ¼" gauge locomotives. Some Hurricanes are being used on 10 ¼" locomotives to good effect!

Months of testing and refinement have led to a product specified to create ample draw for your locomotive and noticeably reduce the time taken for you to get up to steam. The product features a hinged handle for safe removal from the loco when hot and also for compact storage when it's time to head home. If the draw is too great for your loco, a bypass valve/ damper is fitted to pull less air through the chimney and has adjustment depending on your requirements at the time and reduces the potential for thermal shock.



To power the Hurricane, all standard 12V leisure and automotive batteries are appropriate and it is tolerant of up to 14.3V continuous supply. Please be aware that the product will not perform as effectively with an undercharged battery.

Hurricane Blower	HKB-STOCK
------------------	-----------

2023 BROCHURE AND PRICE LIST

Morris Lubricants Oils



For over 150 years, Morris Lubricants has been manufacturing, blending and distributing oils, lubricants and greases to world-class standards in order to meet the specific requirements of their intended purpose. Inclusive of field trials, it can take between five and seven years to bring a product to market, that's why Morris Lubricants support and supply some of the most successful competitors in British and International motorsport including brand ambassador Guy Martin. These competitors know they can trust that these world-class products will serve them in the harshest of competitive environments. We are proud at MRW to be able to offer these high quality oils, which we have personally used in miniature and heritage steam applications for many years.

Type	SKU Prefix	SKU Suffix
220 Classic Bearing Oil 1L, 5L, 25L, 25L with barrel pump	MORRIS-220-B-	1L, 5L, 25L, 25L+PUMP
460 Classic Bearing Oil 1L, 5L, 25L, 25L with barrel pump	MORRIS-460-B-	1L, 5L, 25L, 25L+PUMP
460 Compound Steam Cylinder Oil 1L, 5L, 25L, 25L with barrel pump	MORRIS-460-CSO-	1L, 5L, 25L, 25L+PUMP
680 Compound Steam Cylinder Oil 1L, 5L, 25L, 25L	MORRIS-680-CSO-	1L, 5L, 25L



Boiler Treatment



MRW Atlantic Boiler Treatment is specially formulated to protect locomotive, traction engine and other miniature steam engine boilers against scaling and corrosion. We highly recommend the use of boiler treatment in both steel and copper boyled locomotives to protect against scaling and general corrosion even with distilled and purified waters. With years of use of Tannin boiler treatments in our steel boyled 7 1/4" gauge LNER K2, we believe our all new Atlantic Boiler Treatment will give your locomotive or engine the protection it needs to continue to steam reliably for years to come.

Type	Prefix	Suffix
MRW Atlantic Boiler Treatment 1L/5L/25L	MRW-ATLANTIC-BT-	1L, 5L, 25L

Boiler Descaler

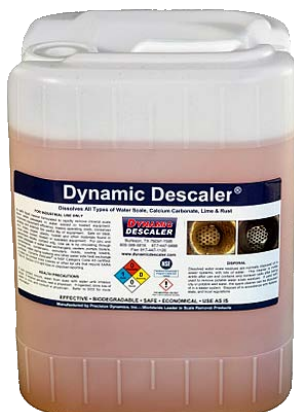

Dynamic Descaler is a safe liquid cleaner formulated to rapidly remove mineral scale from water passages and surfaces in and associated with boilers. It is safe on steel, iron, brass and copper. It is biodegradable and scale residues are normally safe to be disposed of in sewer systems when diluted with lots of water.

Type	Prefix	Suffix
Boiler Descaler 5L/25L	DYNAMIC-DE-	5L, 25L

2023 BROCHURE AND PRICE LIST

Norfolk Tinman Tinsplate Range



Nick is the Norfolk Tinman. He has spent his career working on preserved railways with a wide range of experience of all aspects of locomotive repair. Working for many years as a Fitter at the North Norfolk Railway and volunteering on the footplate as a Driver. He uses his own oil feeders and Tinsmith products on the footplate and we approached him to make a scaled down version of his traditional products.

After some time hand cutting and forming the tinsplate, Nick produced for us an excellent range of both full-sized and scaled down footplate equipment.

Oil Bottles



Handmade oil bottles made using traditional tinsmithing methods. Derived from a traditional style oil bottle, which were widely used across the UK on steam and early diesel locos. The 8pt bottles are faithfully accurate to the originals, whilst the scaled down 3pt and 1pt versions have allowances made to ensure that the handle has the right grip and the design functions correctly in their reduced size forms.

Size	SKU
1 pint	1PT-OIL-NOF-TIN
3 pint	3PT-OIL-NOF-TIN
1 and 3 pint pair	1PT&3PT-OIL-NOF-TIN
8 pint	8PT-OIL-NOF-TIN
Long Neck 1 pint	1PT-LONG-OIL-NOF-TIN

Oil Feeders



LNER & BR Style (Left, foreground) and Midland Style, Right

Handmade oil feeder made using traditional methods by a second generation tinsmith who has years of experience crafting these intricate, practical and functional tools for use at preserved and miniature railways all over the country. Derived from their respective footplate equipment, these oil feeders were widely used across the network on steam and early diesel locos and are faithful to the originals.

The scaled down versions of the originals have allowances to ensure that the handle has the right grip and the design functions correctly in these sizes.

Type	Price Per Item
Half Sized Midland Feeder	HLF-MIDLAND-NOF-TIN
Full Sized Midland Feeder	FUL-MIDLAND-NOF-TIN
Half Sized LNER Feeder	HLF-LNER-NOF-TIN
Full Sized LNER Feeder	FUL-LNER-NOF-TIN



John Beesley Collection of Tinsmithing Works

MRW have recently acquired the entirety of the John Beesley collection of tinsmithing works. John, seen using a feeder of his creation in the image, was an early leader in preserving the skills of tinsmithing for the heritage rail industry.

We were delighted when he reached out to us to pass on his collection of tinsmithing components and tooling. It will be a number of months at the very least before we can entertain any of the main products from John's collection being added to the MRW range, but we are in the process of cataloguing and sorting this huge amount of items.

Miniature Railway Workshop Ltd.

Workshop Materials and Tools

Everything stocked at MRW has been made by MRW or is used and tested by us in our own workshops. We have selected a range of high quality tools and materials for use in the Model Engineers Workshop. We regularly carry out tasks in our workshop of which quality is a key foundation of our work. We have selected a range of products that our customers can trust and rely on for many years.

Locomotive Rolling Road



Available in 7 ½”, 7 ¼”, 5 or 3 ½” Gauges.

Rolling roads are ideal for testing locomotives. Built from 6mm steel plate and using sealed roller bearings, these rolling roads are sturdy and durable and an excellent tool for anyone looking to rebuild and restore miniature locomotives. Sold, assembled and painted ready to use. Manufactured by CMD engineering with over 1000 units sold worldwide, these Rolling Roads have become known for their high quality and durability.

SKU Prefix 3.5-, 5-, 7.25-,7.5-	SKU Suffix ROLL_ROAD
------------------------------------	-------------------------

Profile and Trackwork Gauges

Designed by Colin Edmondson, and MRW for 5”, these gauges are made under licence by MRW with his kind permission. These gauges can be placed over the wheel profiles and trackwork to check they conform with the standards and help eliminate derailments. Made of durable Zintec with both Standard and Narrow gauge profile (7 ¼”), these gauges are designed to last a lifetime.

5” Mainline Standards (Combined Gauge)	5-TW+PROF-GAUGE
7 ¼” Society Profile Gauge	7.25-PROF-GAUGE
7 ¼” Society Trackwork Gauge	7.25-TW-GAUGE



Box Spanners

These are a very handy tool for any model engineer's toolbox and are ideal when trying to tighten nuts in tricky locations. The spanners all have a hole to allow a small metal rod to be inserted to give some extra leverage where required.



At MRW we pride ourselves in promoting UK manufacturing and these box spanners are manufactured by Polly Model Engineering who have been manufacturing steam locomotives at their works in Nottingham since 1999. The Polly range is quite extensive and well worth a browse if you're in the market for a 5 inch steam locomotive. The box spanners are available individually or in sets. See the price list for the full product range.

Type BA Metric	SKU Prefix BOX_SPAN BOX_SPAN	SKU Suffix -BA -ME
----------------------	------------------------------------	--------------------------

Taps and Dies

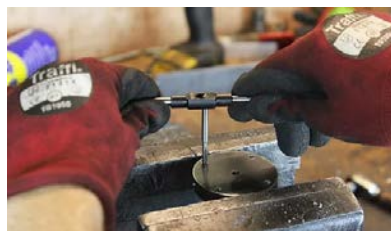

These British manufactured taps and dies suitable for the model engineer and professional alike. The performance of high quality taps is appreciated by anyone with regular metalworking experience - and Apex Tools products are second to none. We can attest to their quality having been put through their paces in our workshop, whether it be brushing off light duties on thin material to rebuilding a loco.

Our range is very large so it is best to consult the price list, however as a summary, we stock the following in carbon steel:- British Standard Brass, British Standard Model Engineer (M.E.), British Standard Whitworth, BA and Metric Coarse. We Stock the following in High Speed Steel which are recommended if you are doing such work as power tapping:- BA and Metric Coarse.

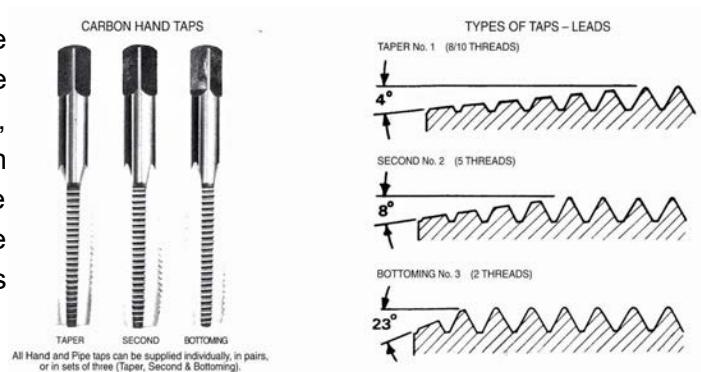

2023 BROCHURE AND PRICE LIST

Vallorbe Swiss Made Metalworking Files & Needle File Sets

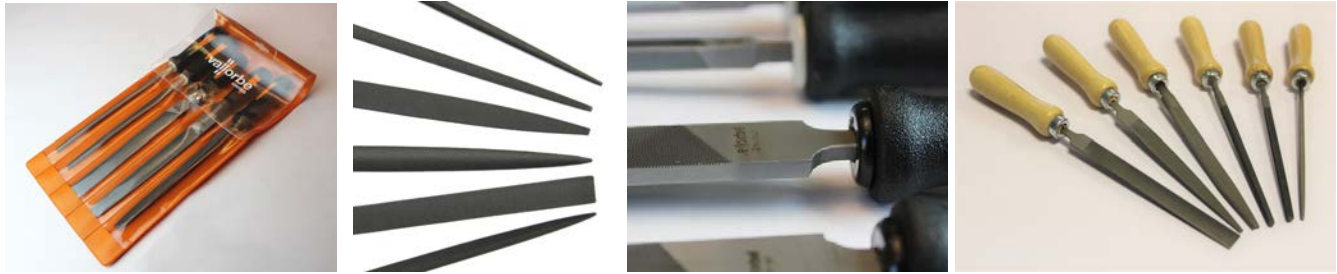

We endeavour to supply British made products wherever possible, however there are sadly no longer any manufacturers of files remaining in this country. We use Vallorbe files in our product manufacture and can attest to their quality and longevity. Any person who has been involved with engineering from full scale steam locos to tabletop miniatures appreciates the true value of high quality metalworking files; these are some of the finest available on the market.

Needle File Type	SKU
(Classic) 0 Cut set of 5 7.5cm Cutting Edge	VLAM020-140-0
(Classic) 2nd Cut set of 5 7.5cm Cutting Edge	VLAM020-140-2
(Premium) 0 Cut set of 5 9cm Cutting Edge	VLA2443-0
(Premium) 2nd Cut set of 5 9cm Cutting Edge	VLA2443-2
Engineer's File (above middle)	
100mm Engineers Files, Set of 6 (Second Cut)	LQ5450-4
Metalworking File	
Second Cut 8" set of 5 18cm Cutting Edge	VLX5930-8-2
Second Cut 10" set of 5 18cm Cutting Edge	VLX5930-10-2

Cutting Oils



Morris Supercut 1000 is a water soluble metalworking fluid of the traditional type. It is manufactured from high quality paraffinic base oils with added preservatives along with lubricity and anti-corrosion additives. The product is readily miscible with most mains water to form a stable, rich, milky white emulsion of low odour and good corrosion protection. Supercut 1000 may be used in a wide variety of applications e.g. Turning (including light automatic work), milling, drilling, boring and shaping.

Type	SKU Prefix	SKU Suffix
Supercut 1000, 5L, 25L, 25L + pump	MORRIS-1000-S-	5L, 25L, 25L+PUMP

EN8 Round Bar

EN8 is an engineering steel, also known as 080M40. EN8 is the ideal choice for many model engineering operations where a bright finish is required and wear and strength are both considerations. It is a harder metal to machine/turn than normal mild steel but has much better wear resistance making it an ideal choice for locomotive/carriage axles. EN8 is also widely used for locomotive wheels and can be hardened/heat treated to add wear resistance. It is suitable for shafts, stressed pins, keys and various other applications.

Postage is calculated by weight, please consult the postage table to better understand the postage price.

6mm Diameter	8mm Diameter	10mm Diameter
0.14kg per 60cm	0.24kg per 60cm	0.38kg per 60cm
6MM-EN8-60CM	8MM-EN8-60CM	10MM-EN8-60CM

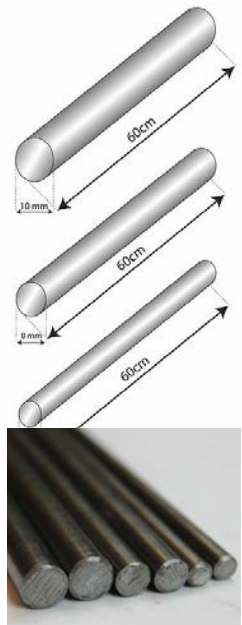

Crank Handles

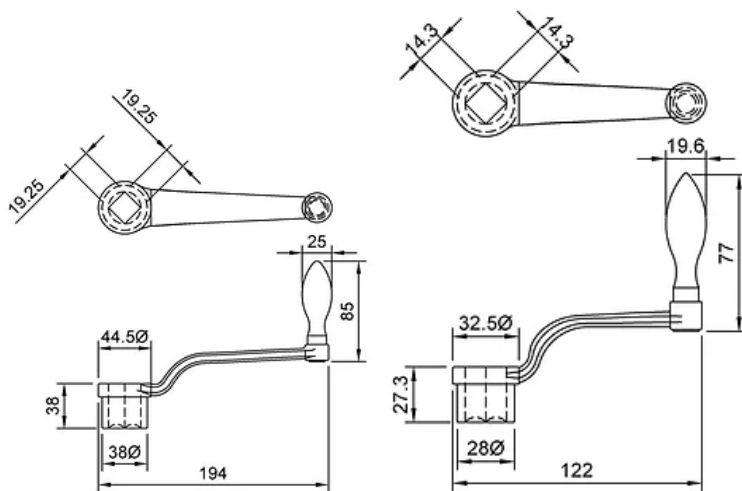

Weight Each (KG) : 0.3, 0.7

14.3mm ½" Square	½-CRANK
19.25mm ¾" Square	¾-CRANK

These crank handles are ideal replacements for your milling machine vice and are well made meaning they will last many years of reliable use. The arm is painted cast iron with zinc plating on the handle and bare metal on the mating surface.



Repair & Refurbishment



At MRW we have a versatile workshop where we build many of the products you can find in this brochure. Alongside our normal production work, we also take on various locomotives, rolling stock and track for repair. Examples of this includes; rewiring of electric locos, reprofiling of wheelsets, custom one-off machining, and point/track repair (especially existing portable track.) We have also taken on a number of locomotives in need of full re-builds, such as 7 1/4" Holmside loco and a large class 47. Here at MRW we are always happy to discuss work on miniature trains, so please do give us a call.



Signs and Lineside Equipment

We are offering a growing range of products suited to both size and miniature railways that do not fall into the category of track or rolling stock. We are now manufacturing speed signs and point levers with more products to come in the near future.



Colin Edmondson Permanent Point Lever



Now available from MRW - the Colin Edmondson trailable point lever. This point lever is a commercial grade lever supplied with a straight and 90 degree arm to allow it to be positioned in a way that best suits your space. The lever is fully welded and assembled by us in our Nottingham workshop in partnership with Colin.

With a 5kg pull and 30mm throw, this lever is well suited for use up to the largest rail profiles used on 10 ¼" gauge lines. Its sturdy 6mm plate construction means that with regular maintenance and lubrication, it will work without issue for many years. Supplied unpainted, these point levers are lockable via pin and are another excellent example of Colin Edmondson's reputable designs that work beautifully in the real world.

Colin Edmondson Permanent Point Lever	CE-POINT-LEVER
---------------------------------------	----------------

2023 BROCHURE AND PRICE LIST

Full Size Speed Signs

Prototypical of the speed signs used by LNER and later BR, these signs were a common feature across the network in the UK. Originally the signs were flame cut using a template hence there were quite a lot of very subtle variations. These signs have been made using an original as a guide, with the font and dimensions very carefully recreated to give an accurate version of the original. The signs bolt on to our 2.5m posts and are supplied either un-painted or painted. Direction arrows simply bolt on using pre-drilled holes in the post.



Full size Speed Sign	Un-Painted
Direction Arrow	SPEED-S-FS-D/A
5	SPEED-S-FS-5
10	SPEED-S-FS-10
15	SPEED-S-FS-15
25	SPEED-S-FS-25
40	SPEED-S-FS-40
100	SPEED-S-FS-100
125	SPEED-S-FS-125
Other speeds available to order	POA
2.5m long post (nuts / bolts included)	SPEED-S-FS-P



2023 BROCHURE

Quarter size speed signs

An exact quarter scale version of the real thing, these are ideal for most miniature railways being large enough to be seen but not out of place compared to standard or narrow gauge rolling stock in 5" - 10¼"

The signs bolt on to our 0.6m posts and are supplied either un-painted or painted. Direction arrows simply bolt on using pre-drilled holes in the post.

Other scales (1/8th and 1/2th) are both in development. Please contact us for details.

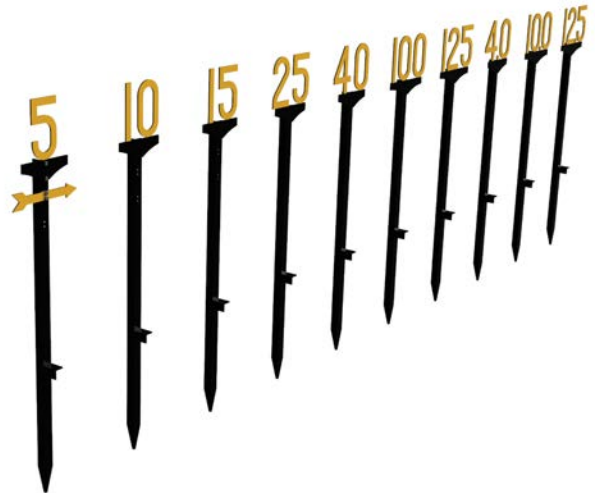

Quarter size Speed Sign	SKU
Direction Arrow	SPEED-S-¼-D/A
5	SPEED-S-¼-5
10	SPEED-S-¼-10
15	SPEED-S-¼-15
25	SPEED-S-¼-25
40 & 4.0	SPEED-S-¼-40
100 & 10.0	SPEED-S-¼-100
125 & 12.5	SPEED-S-¼-125
Other Speeds available to order.	POA
0.65m Long post Nuts / Bolts Included	SPEED-S-¼-P



Publications

By Colin Edmondson



Two books are available from Colin Edmondson. The first is *The Story of the Scamp*. This book documents the development of the Scamp Locomotive but also Colin’s design and engineering background which has led him to become one of the most influential designers in the miniature railway landscape. Included are some wonderful details about Colin’s background and first forays into railways with details of how he became a pioneer in the minimal gauge railways movement which has developed over the last few decades. Regardless of whether you actually own a scamp you will enjoy this 43 page book packed full of miniature railway information and photos.

The second is *How to Build Your Own 7 1/4” Gauge Points from Bar Stock*. This is another excellent detailed book by Colin detailing how to make 7 1/4” gauge points from flat steel bar stock. The book is supplied with gauge holding guides and details information on standard points, three way points, Y shaped points and dimensions for various radiuses. Produced to 7 1/4” Gauge Society standards, this book is a must have for anyone looking to build not only flat bar points, but also as a useful reference for profile or box rail points.

<p>The Story of the Scamp How to Build Your Own 7 1/4” Gauge Points from Bar Stock</p>	<p>CE-SOS-BOOK CE-BYOP-BOOK</p>
--	-------------------------------------

MRW Brochure and Price List

The MRW brochure with a full list of products. Available for fast delivery for a small fee to browse at your leisure or for quick reference!

<p>Printed Copy of MRW Brochure and Price List</p>	<p>MRW-BROCHURE</p>
--	---------------------

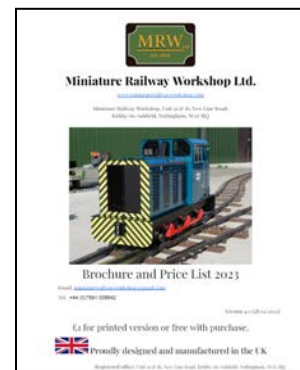

Postage and Collection

Updated FEB- 2023



UK - Mainland Standard Shipping Rates			Our postage is calculated by product weight. Please consult the weight shown next to each product in this price list. If using the website; add items to your cart and check at your order summary for the calculated price..
Weight (KG)		Price	
From	To		
0	5	£5	
5	30	£30	
30	55	£55	
55	80	£80	
80	100	£100	
100	+	£120	

Non-Main Land and Global Shipping Rates	Please contact us for a quote.
--	---------------------------------------

Collecting from MRW	<p>Collections need to be pre-arranged so we can plan appropriately. Our workshop is small but efficient, meaning we can not have multiple visiting groups at once. Please do make contact before collection.</p>
----------------------------	---

**Please read our Terms & Conditions Policy found on our website.
 MRW.Ltd. reserves the right to change postage costs.**

UK based!

MRW is based from Nottingham for all production and sales. This is a massive step forward with much more room to expand and grow. Thanks for your continued support and we hope to welcome you in the future for collections and open days.



What's Next?

We are working to develop more products to expand our range to include more gauges and track components. We are also looking to offer more products outside of our current offering that would be of interest to the hobbyist and the model engineer. If you have a product that you would like to see us make, we encourage you to get in touch.



Contact

Web: www.miniaturerailwayworkshop.com
Email: miniaturerailwayworkshop@gmail.com
Tel: 07591 006642

MRW. Unit 1a & 1b, New Line Road, Kirkby-In-Ashfield, Nottingham, NG17 8JQ

Registered Address: Miniature Railway Workshop, Unit 1A & 1B, New Line Road, Kirkby-In-Ashfield, Nottingham, NG17 8JQ



Pricing

Whilst we make every effort to hold pricing, we reserve the right to amend and alter the prices displayed in this brochure. Materials, labour and running costs can undergo significant changes throughout the year based on global market conditions and like any business, we are directly subjected to these fluctuations.

Payment Terms for all Miniature Railway Workshop Products

Standard items are available to buy through the MRW online shop.

www.miniaturerailwayworkshop.com/shop

Enter the number of items you require and press "add to basket" this will be added to the virtual 'basket.' More items can be added to the basket as needed. The final total will include our standard delivery costs. Details can be found above or on our website.

Subject to availability, there is sometimes a lead time on track products. If placing an order for more than 30 sections or if you require a non-standard item, please contact us directly with your requirements and a price can be quoted. When placing large orders you will be asked for a deposit that is non-refundable.

Return & Refund Policy

We offer a 14 days return policy, provided the item is in the same condition that it was sold in. We will refund the price of the items minus the cost of delivery.

Note: buyers pay return delivery costs.

For more info on our [Terms & Conditions](#) head to our website

[Full copy of our Terms and Conditions can be found on our website:](#)

www.miniaturerailwayworkshop.com/terms-conditions

The Portable Railway Club

The Portable Railway Club is a Non-Profit Organisation Supported by MRW for the promotion of portable railways. The club operates running days where members can freely participate and visitors are able to buy tickets to ride on the trains

The purpose of the club is to showcase our 7 ¼” and 5” gauge Jubilee track and give new and potential customers the opportunity to experience rides on a miniature railway.

Since MRW was founded in 2018 we’ve made and sold our Jubilee track panels to hundreds of satisfied customers.

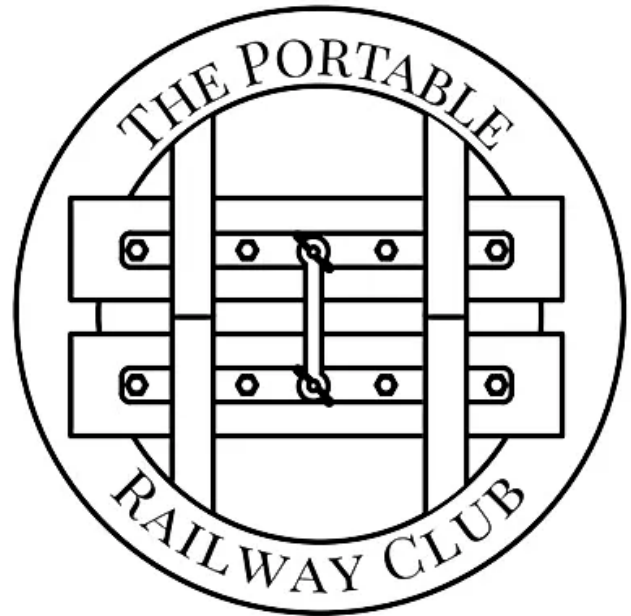

Membership for one year of the Portable Railway Club (PRC).

Adult Membership of the Portable Railway Club **£4.00**
 Youth Membership of the Portable Railway Club **£2.00**

All money raised goes directly towards the PRC which is a Non-profit organisation with Public liability for passenger carriage.

Your membership will give you free rides on the railway, the ability to help us run and build the railway, plus access to members only event days and a wealth of club member knowledge on loco building & operation.

MRW 2023 Pricing



Thank you to all our customers who have supported us and sent in pictures of the products we have Designed/Made/Sold from right here in the UK.

